

# CLUX-SDI2HC

## 3G SDI Extender with HDMI Converter

*Operation Manual*



## • **Disclaimers**

The information in this manual has been carefully checked and is believed to be accurate. Cypress Technology assumes no responsibility for any infringements of patents or other rights of third parties which may result from its use.

Cypress Technology assumes no responsibility for any inaccuracies that may be contained in this document. Cypress also makes no commitment to update or to keep current the information contained in this document.

Cypress Technology reserves the right to make improvements to this document and/or product at any time and without notice.

## • **Copyright Notice**

No part of this document may be reproduced, transmitted, transcribed, stored in a retrieval system, or any of its part translated into any language or computer file, in any form or by any means - electronic, mechanical, magnetic, optical, chemical, manual, or otherwise - without express written permission and consent from Cypress Technology.

© Copyright 2009 by Cypress Technology.  
All Rights Reserved.  
Version 1.0 October 2009

## • **Trademark Acknowledgments**

All products or service names mentioned in this document may be trademarks of the companies with which they are associated.

## • **Safety Precautions**

Please read all instructions before attempting to unpack or install or operate this equipment, and before connecting the power supply. Please keep the following in mind as you unpack and install this equipment:

- Always follow basic safety precautions to reduce the risk of fire, electrical shock and injury to persons.
- To prevent fire or shock hazard, do not expose the unit to rain, moisture or install this product near water.
- Never spill liquid of any kind on or into this product.
- Never push an object of any kind into this product through module openings or empty slots, as you may damage parts.
- Do not attach the power supply cabling to building surfaces.
- Do not allow anything to rest on the power cabling or allow it to be abused by persons walking on it.
- To protect the equipment from overheating, do not block the slots and openings in the module housing that provide ventilation.

## • **Revision History**

<b>Version No</b>	<b>Date</b>	<b>Summary of Change</b>
<b>V1</b>	<b>20100607</b>	<b>Preliminary Release</b>
<b>VR2</b>	<b>20101202</b>	<b>Storage Temperature</b>

# ***Table of Contents***

<b>1. Introduction.....</b>	<b>1</b>
<b>2. Applications.....</b>	<b>1</b>
<b>3. Package Contents .....</b>	<b>1</b>
<b>4. Features .....</b>	<b>1</b>
<b>5. System Requirements.....</b>	<b>1</b>
<b>6. Specifications .....</b>	<b>2</b>
<b>7. Operation Controls and Functions.....</b>	<b>3</b>
7.1 Front Panel.....	3
7.2 Rear Panel .....	4
<b>8. Connection and Installation .....</b>	<b>5</b>

## 1. Introduction

The SDI to HDMI converter allows SD-SDI, HD-SDI and 3G-SDI signals to be shown on HDMI/SDI displays while ensuring high bit rates of 2.970 Gbit/s to give you fast signal transmission without any loss. For professionals this means that it is now easier to distribute and extend your 3G SDI signal while giving you the ability to display your work on HDMI displays thanks to the built in HDMI converter. Furthermore, thanks to the loop-through 3G-SDI design, users are able to enjoy both SDI and HDMI displays at the same time.

## 2. Applications

- Connect to multiple displays by linking one 3G SDI Extender to another through its SDI output port. When connected to another 3G SDI Extender, you can broadcast a signal to two HDMI displays and one SDI display, or connect to another Extender to provide more connections and a longer operating distance.
- Convert 3G SDI to HDMI

## 3. Package Contents

- 3G SDI to HDMI Converter
- 5V/2.6A DC power adaptor
- Operation Manual

## 4. System Requirements

Input broadcast video with an SDI cable and output to SDI and/or HDMI displays with included connection cables.

## 5. Features

- Operation at 2.970Gbit/s, 2.970/1.001Gbit/s, 1.485Gbit/s, 1.485/1.001Gbit/s and 270Mbits/s
- Supports SMPTE 425M (Level A and Level B), SMPTE 424M, SMPTE 292M, SMPTE 259M-C
- Equalized and re-clocked loop output
- Integrated audio de-embedder for a maximum of 8 channel, 48 kHz audio
- Auto video mode detection (3G/SD/HD)
- Conversion from SMPTE 425M level B to Level A 1080p 50/59.94/60 4:2:2 10-bit
- Connect with other units to extend your signal over long distances
- Simultaneous display with SDI and HDMI signals
- Supports signal transmission distances of up to 300M for SDI signals, 200M for HD signals and 100M for 3G signals

**Note:** Cable tested with Belden 1694A. Operating distances may vary if used with another type of cable.

## 6. Specifications

SMPTE Standard	425M Level A & B, 424M, 292M, 259M-C
SDI Transmission	Rates 2.970 Gbit/s and 2.970/1.001 Gbit/s
Frequency Bandwidth	225MHz/link (HDMI 1.3)
Input Port	1 x BNC (SDI/HD-SDI/3G-SDI)
Output Port	1 x BNC (SDI/HD-SDI/3G-SDI), 1 x HDMI, 2 x RCA Jack
Video Supports	480i, 576i, HD-SDI-720p, 1080i, 3G-SDI-1080p
Power Supply	5V DC/ 2.6A (US/EU standards, CE/FCC/UL certified)
ESD Protection	Human body model: $\pm 8$ kV (air-gap discharge) $\pm 4$ kV (contact discharge)
SDI Cable Distance	3G up to 100M (BELDEN 1694A) HD up to 200M (BELDEN 1694A) SD up to 300M (BELDEN 1694A)
Dimension (mm)	137(W) x 90(D) x 25(H)
Weight (g)	225
Chassis Material	Aluminum
Silkscreen Color	Black
Operating Temperature	0°C ~ 40°C / 32°F ~ 104°F
Storage Temperature	-20°C~60°C / -4°F ~ 104°F
Relative Humidity	20 ~ 90% RH (Non-condensing)
Power Consumption (W)	4

## 7. Operation Controls and Functions

### 7.1 Front Panel

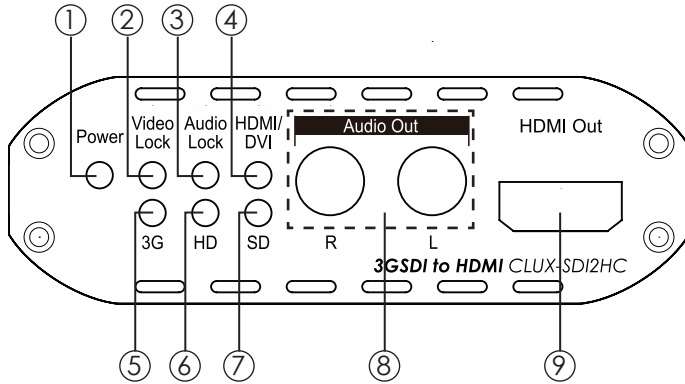

- ①. Power LED: This red LED will switch on when the device is connected with the power supply.
- ②. Video Lock LED: This green LED will turn on when both the input SDI source and the output HDMI display have sent and received a signal.
- ③. Audio Lock LED: This green LED will switch on when the input SDI source has an audio signal and when the output HDMI/DVI display activates.
- ④. HDMI/DVI LED: This green LED will turn on when connected to an HDMI display and will not switch on when connected to a DVI display. The device will read the output display's EDID to determine whether to send an HDMI or DVI signal.
- ⑤. 3G LED: This yellow LED will turn on when the input SDI signal is 3G.
- ⑥. HD LED: This yellow LED will switch on when the input SDI signal is HD.
- ⑦. SD LED: This yellow LED will turn on when the input SDI signal is SD.
- ⑧. Audio out R/L: These slots are where you connect an amplifier with a RCA jack to, in order to transmit an audio signal.
- ⑨. HDMI Out: This slot is where you connect a HDMI / DVI display with a HDMI or HDMI to DVI cable to.

## 7.2 Rear Panel

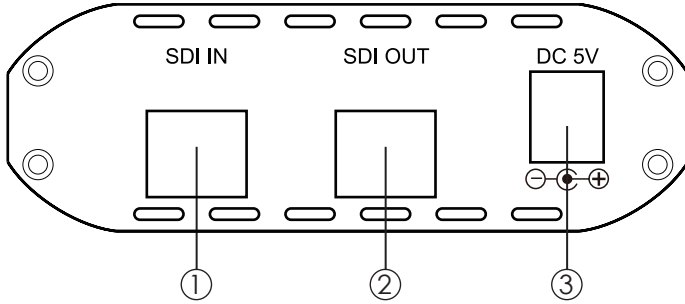

- ①. SDI IN: This slot is where you connect the SDI source to, in order to send a SDI signal to a display.
- ②. SDI OUT: This slot is where you connect the SDI display to, with an SDI cable for displaying images. Connect it to another SDI to HDMI converter/ extender to extend your signal or connect to multiple displays.
- ③. DC 5V: Plug the 5V DC power supply into the unit and connect the adaptor to an AC outlet. The red LED will turn on when the power is on.



## 8. Connection and Installation



Video Camera

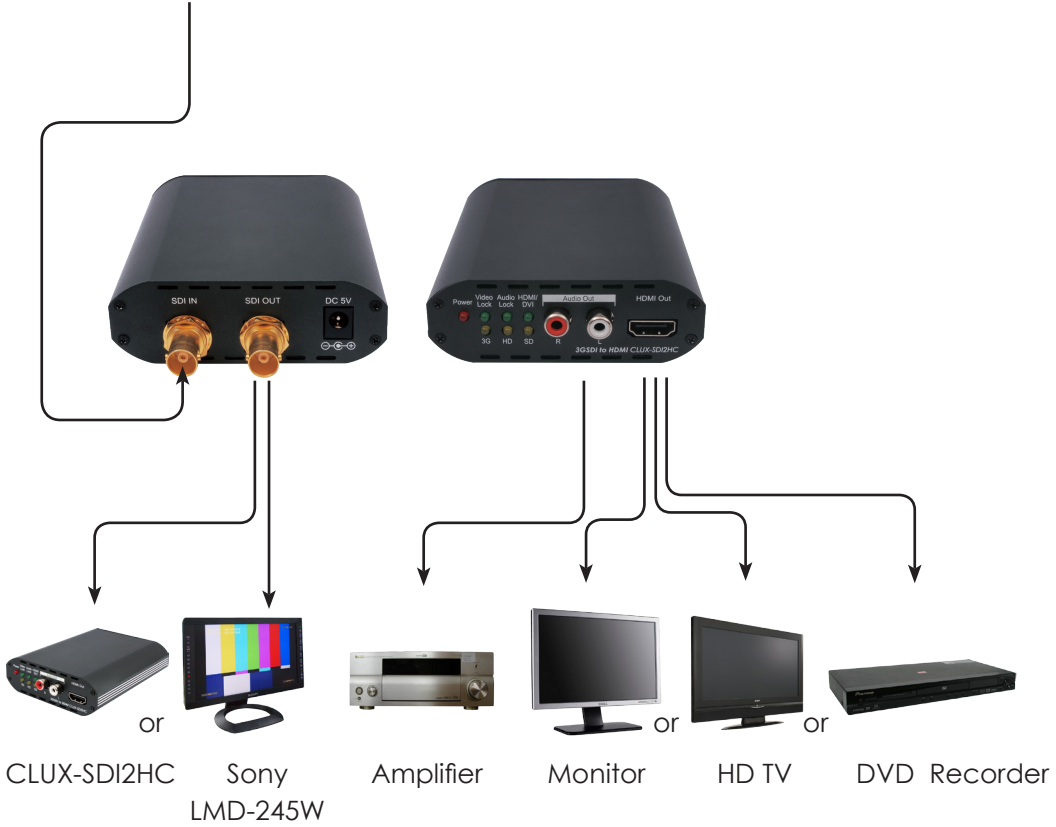

# Acronyms

---



## **Acronym**

## **Complete Term**

3G

Bandwidth 2.97Gbit/s  $\approx$  3G

SDI

Serial Digital Interface





**CYPRESS TECHNOLOGY CO., LTD.**  
Home page: <http://www.cypress.com.tw>

MPM-SDI2HC