



CDPS-CS7-S

IP Master Controller (SDVoE)
(Phase 2)



Operation Manual



HDMI®
HIGH-DEFINITION MULTIMEDIA INTERFACE

The terms HDMI, HDMI High-Definition Multimedia Interface, and the HDMI Logo are trademarks or registered trademarks of HDMI Licensing Administrator, Inc.

DISCLAIMERS

The information in this manual has been carefully checked and is believed to be accurate. Cypress Technology assumes no responsibility for any infringements of patents or other rights of third parties which may result from its use.

Cypress Technology assumes no responsibility for any inaccuracies that may be contained in this document. Cypress also makes no commitment to update or to keep current the information contained in this document.

Cypress Technology reserves the right to make improvements to this document and/or product at any time and without notice.

COPYRIGHT NOTICE

No part of this document may be reproduced, transmitted, transcribed, stored in a retrieval system, or any of its part translated into any language or computer file, in any form or by any means—electronic, mechanical, magnetic, optical, chemical, manual, or otherwise—without express written permission and consent from Cypress Technology.

© Copyright 2018 by Cypress Technology.

All Rights Reserved.

TRADEMARK ACKNOWLEDGMENTS

All products or service names mentioned in this document are trademarks of the companies with which they are associated.



SAFETY PRECAUTIONS

Please read all instructions before attempting to unpack, install or operate this equipment and before connecting the power supply. Please keep the following in mind as you unpack and install this equipment:

- Always follow basic safety precautions to reduce the risk of fire, electrical shock and injury to persons.
- To prevent fire or shock hazard, do not expose the unit to rain, moisture or install this product near water.
- Never spill liquid of any kind on or into this product.
- Never push an object of any kind into this product through any openings or empty slots in the unit, as you may damage parts inside the unit.
- Do not attach the power supply cabling to building surfaces.
- Use only the supplied power supply unit (PSU). Do not use the PSU if it is damaged.
- Do not allow anything to rest on the power cabling or allow any weight to be placed upon it or any person walk on it.
- To protect the unit from overheating, do not block any vents or openings in the unit housing that provide ventilation and allow for sufficient space for air to circulate around the unit.
- Please completely disconnect the power when the unit is not in use to avoid wasting electricity.

VERSION HISTORY

REV.	DATE	SUMMARY OF CHANGE
RDV1	2019/05/09	Preliminary release (Phase 1)
RDV2	2019/12/09	Phase 2 technical review

CONTENTS

1. Introduction	1
2. Applications	1
3. Package Contents	2
4. System Requirements	2
5. Features	2
6. Operation Controls and Functions	3
6.1 Front Panel.....	3
6.2 Rear Panel.....	3
6.3 Remote Control	4
6.4 IR Cable Pinouts.....	5
6.5 RS-232 Pinout and Defaults	5
6.6 WebGUI Control	6
6.6.1 Monitor & Control Tab.....	8
6.6.2 System Tab.....	21
6.6.3 Settings Tab.....	24
6.6.4 Transmitter Tab.....	35
6.6.5 Receiver Tab	39
6.6.6 Scaling Tab.....	43
6.6.7 Video Wall Tab.....	44
6.6.8 Multiview Tab.....	46
6.7 Telnet Control	48
6.8 RS-232 and Telnet Commands	49
7. Connection Diagram	60
8. Specifications	61
8.1 Technical Specifications	61
8.2 Video Specifications	62
8.3 Cable Specifications	64
9. Acronyms	65





1. INTRODUCTION

This IP Master Controller is a powerful and flexible solution for controlling multiple SDVoE (Software Defined Video over Ethernet) based extenders within same network. The user only needs to install this unit into the same local network as the extenders (transmitters and receivers) to easily define and configure channel routing selections (including video, audio, and a variety of control interface types) using the WebGUI. Without the use of this centralized control unit, each transmitter and receiver pair would only be able to function in a point-to-point capacity.

Additionally, this unit supports controlling and configuring the matrix, video wall, and multiviewer modes of connected SDVoE units. The settings of all connected transmitter/receiver units, including IP configuration, compatibility settings, and extender status are clearly displayed within the WebGUI. A trigger input interface is also provided to allow the easy addition of a remote control keypad, or other trigger-supporting products, which can be installed within a podium or table in a conference room or classroom. This interface can allow the user to activate stored macros with the simple press of a button. Standard control is available via WebGUI (remote or local), RS-232, Telnet and IR Remote.

2. APPLICATIONS

- Video/TV wall display and control
- Security surveillance and control
- Commercial advertising, display and control
- Home Theaters with Smart Home Controls
- Retail sales and demonstration

3. PACKAGE CONTENTS

- 1× IP Master Controller (SDVoE)
- 1× 5V/2.5A DC Power Adapter
- 1× Terminal Block (3-pin)
- 3× Terminal Block (5-pin)
- 1× IR Extender Cable
- 1× Remote Control (CR-183)
- 1× Shockproof Feet (Set of 4)
- 1× Operation Manual

4. SYSTEM REQUIREMENTS

- An active network connection from a switch or router for control of compatible AV over IP devices.

5. FEATURES

- Enables the management and configuration of multiple compatible SDVoE extenders through a single WebGUI
- Provides control over the independent routing of video, audio and control signals between all local compatible transmitters and receivers
- Control over matrix, video wall, and multiviewer modes using WebGUI macros
- WebGUI clearly displays the status of all connected Transmitters and Receivers, including IP address, channel selection, etc.
- Can generate serial commands to directly control an external serial-controllable device
- Can be powered by Ethernet switches supporting the IEEE 802.3af 2003 PoE standard (Optional)
- Trigger Control Keypad support for easy, single-button, macro activation (Optional)
- Standard control is available via WebGUI (remote or local), RS-232, Telnet, and IR Remote

6. OPERATION CONTROLS AND FUNCTIONS

6.1 Front Panel

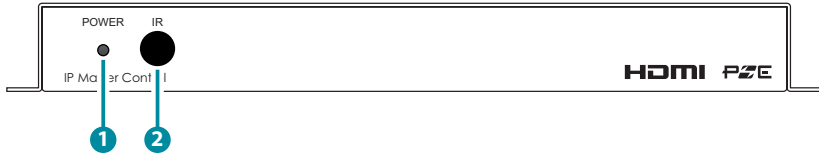

- 1 POWER LED:** This LED will illuminate to indicate the unit is on and receiving power.
- 2 IR Window:** Accepts IR signals from the included IR remote for control of this unit only.

6.2 Rear Panel

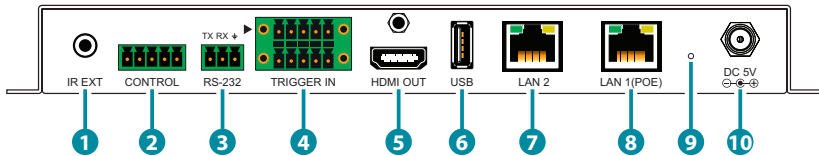

- 1 IR EXT Port:** Connect to the provided IR Extender to extend the IR control range of the unit. Ensure that the remote being used is within direct line-of-sight of the IR Extender.
- 2 CONTROL 5-pin Terminal Block:** Connect to a serial controllable device for the transmission of RS-232 signals.
- 3 RS-232 3-pin Terminal Block:** Connect to a PC, laptop or other serial control device with a 3-pin adapter cable to control the unit via RS-232.
- 4 TRIGGER IN 10-pin Terminal Block:** Connect to the Trigger Control Keypad (OPTIONAL) or any device with trigger switch functionality such as window security alarms, motion detectors, door switches, etc. Each of the 8 trigger inputs will activate the associated macro (1~8) when triggered.

Note: A minimum of 5V DC is required to activate each trigger.

- 5 HDMI OUT Port:** Connect to a standard HDMI display to view the unit's current status information and access the WebGUI directly without a PC.

Note: HDMI output is locked to a resolution of 1080p@60Hz.

- 6 **USB Port:** Connect a USB mouse and keyboard to control the unit's WebGUI displayed on the HDMI output port. Firmware update via USB is also supported.

Note: Specialized USB control devices, such as a touch panel, should be connected before the unit is powered on.

- 7 **LAN 2 Port:** Connect directly, or through a network switch, to your PC/laptop to control the unit via WebGUI/Telnet.

- 8 **LAN 1(POE) Port:** This port is used to connect to the SDVoE devices to be controlled. Connect to the SDVoE units' private network through their dedicated network switch, to enable detection and control over those units.

Note: If the connected network switch supports the IEEE 802.3af 2003 PoE (Power over Ethernet) standard, this unit can optionally be powered directly via this Ethernet port.

- 9 **FACTORY RESET Pinhole:** Press and hold for 3 seconds to reset the unit to its factory defaults, including Ethernet settings.

Note: While the reset is in process, the LEDs on the front of the unit will flash. Once the reset is complete, the unit will return to normal operation.

- 10 **DC 5V Port:** Plug the 5V DC power adapter into the unit and connect it to an AC wall outlet for power. (Optional, not required if the unit is powered via PoE).

6.3 Remote Control

- 1 **PRESET 1~8:** Press any of the 8 buttons to activate the saved preset associated with that number.

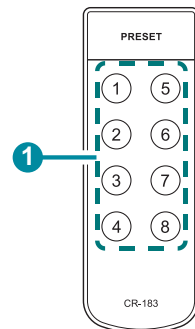

6.4 IR Cable Pinouts

IR Extender Cable

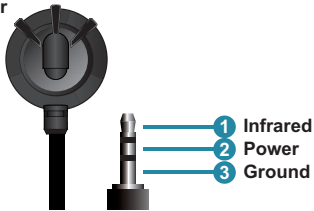

6.5 RS-232 Pinout and Defaults

Serial Port Default Settings	
Baud Rate	19200
Data Bits	8
Parity Bits	None
Stop Bits	1
Flow Control	None

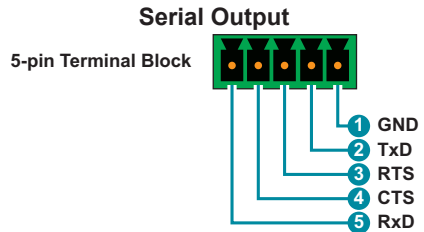
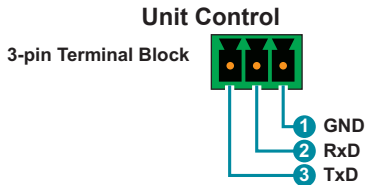

6.6 WebGUI Control

• Device Discovery

Please obtain the “Device Discovery” software from your authorized dealer and save it in a directory where you can easily find it.

Connect the unit and your PC/Laptop to the same active network and execute the “Device Discovery” software. Click on “Find Devices on Network” and a list of devices connected to the local network will show up indicating their current IP address.

Note: This unit defaults to DHCP mode. The current IP address can be verified using the HDMI output or RS-232 if the Device Discovery software is not available.

Find Devices on Network			
Product Name	Description	IP Address	MAC Address

By clicking on one of the listed devices you will be presented with the network details of that particular device.

Product ID	
Product Name	
MAC Address	00:00:00:00:00:00
IP Address	<input type="text"/>
Subnet Mask	<input type="text"/>
Gateway IP	<input type="text"/>
DNS	<input type="text"/>
IP Mode	Static
Web GUI Port	Static
Telnet Port	0
S / N	
Firmware Version	
Hardware Version	
Description	
Web GUI	Web GUI
Save	Reboot

- 1) IP Mode:** If you choose, you can alter the static IP network settings for the device, or switch the unit into DHCP mode to automatically obtain proper network settings from a local DHCP server. To switch to DHCP mode, please select DHCP from the IP mode drop-down, then click “Save” followed by “Reboot”.
- 2) WebGUI Hotkey:** Once you are satisfied with the network settings, you may use them to connect via Telnet or WebGUI. The network information window provides a convenient link to launch the WebGUI directly.

- **WebGUI Overview**

After connecting to the WebGUI's address in a web browser, the WebGUI will load and display the System tab. Click "Login" to open the authentication window. Please enter the appropriate user name and password then click "Enter" to log in. If a keyboard is not available, such as when using a touch screen, an on-screen keyboard can be activated by clicking on the keyboard icon (🗂️).

Note: The default user name and password is "admin".

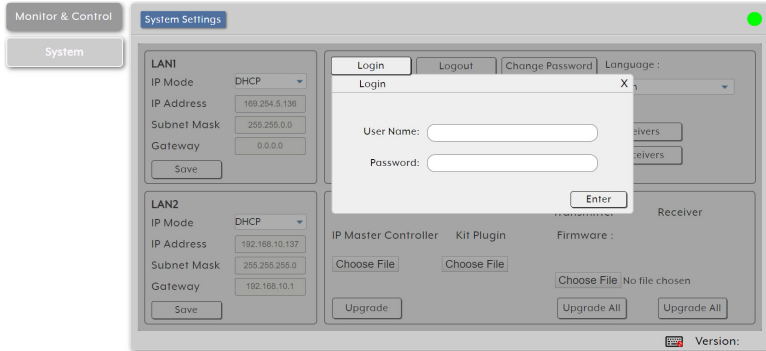

After logging in, on the left side of the browser you will see the following menu tabs where all primary functions of the unit are controllable via the built in WebGUI. The individual functions will be introduced in the following sections.

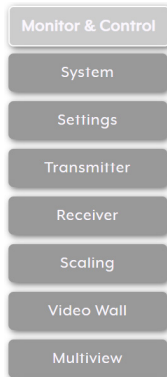

Clicking the "Logout" button within the "System" tab will log the currently connected user out of the WebGUI and return to login page.

Note: When not logged in, only the "Monitor & Control" and "System" tabs are available.

6.6.1 Monitor & Control Tab

This tab provides easy to use drag-and-drop control over all basic routing functionality of the transmitters and receivers that have been detected within the local network. In all sections, except for the Video section, transmitters are represented by the source icon (📺) and receivers are represented by the display icon (📺). Each of this tab's sections control the routing of a different type of interface that can be found on most compatible transmitters, receivers or transceivers. These interfaces are: Video routing, Video Wall routing, Multiview selection, HDMI Audio routing, Analog Audio routing, USB routing, IR routing, RS-232 routing, and Macro activation. This tab's controls are available even when a user is not logged in, providing basic control over routing without exposing system critical configuration areas.

Note: Units that were previously a part of the system, but are not currently detected will still be displayed, however they will have a disconnected icon (📺) and cannot be used for routing.

- 1) **Video Routing:** Provides drag-and-drop control over the video routing between all detected transmitters and receivers. Each transmitter and receiver box will display a small, low framerate, video thumbnail to indicate what video is currently active.

Note: Certain operational modes (multiview, video wall) and some transmitters and receivers do not support the video thumbnail feature.

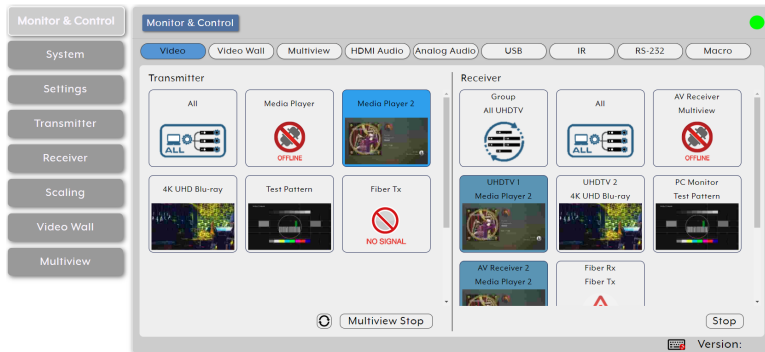

- **Video Transmitter:** This section provides drag-and-drop buttons for all transmitters detected by the system as well as a multi-option button target to stop video streams from being transmitted.

Note: The IP Master Controller has an automatic bandwidth reduction feature to prevent situations where a source's streams will exceed 10Gbps, but in the unlikely event a transmitter's streams still require more bandwidth than is available, the video output may become visually unstable. In these situations it is recommended to reduce the resolution, framerate, or bit depth of the original source.

Source to Single Receiver Routing: To route a source to a receiver, click and drag the source's button on the left to the preferred display on the right side, then release the mouse button. If the routing was completed successfully, the newly routed source's name will appear below the display's name within the button. Clicking on any source button will change the color of itself, and all currently routed displays.

Note: Receivers may also be drag and dropped onto sources to activate a new route.

Source to Multiple Receiver Routing: To route a source to multiple receivers at the same time, click and drag the source's button on the left to a pre-defined Video Group or "All" button on the right side, then release the mouse button. If the routing was completed successfully, the source's name will appear within all appropriate buttons.







All/Native/Multiview Stream Stop: In certain situations it may become necessary to stop one or all of the video streams coming from a source. To do this, first select the type of stream to stop by clicking on the cycle selection icon (Ⓢ) at the bottom of the window until the preferred option (All Stop, Native Stop, Multiview Stop) is displayed. Next, click and drag the source down to the chosen "Stop" button. The chosen stream type will be immediately terminated. To stop a stream type from ALL video streams simultaneously, drag the "All" button down to the chosen "Stop" button.

"All Stop" stops all stream types from the selected source, "Native Stop" stops only the full resolution primary video stream, "Multiview Stop" stops only the secondary video stream used by multiviewer layouts.

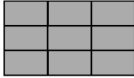
- **Video Receiver:** This section provides drag-and-drop buttons for all receivers detected by the system as well as a button target to stop one or all output streams from being displayed.

Stop Stream: To stop the video stream on a single display, drag the display down to the “Stop” button at the bottom of the window, then release the mouse button. To stop ALL video outputs, drag the “All” button down to the “Stop” button.

- **Status Icons:** Status icons will be displayed instead of a video thumbnail image under the following conditions:

	<p>Displayed when a receiver is in Video Wall mode.</p>
	<p>Displayed when a receiver is in Multiviewer mode.</p>
 <p>NO SIGNAL</p>	<p>Displayed when a transmitter’s current input has no live source connected.</p>
 <p>NOT CONNECTED</p>	<p>Displayed when a receiver does not have an active display connected.</p>
	<p>Displayed when a transmitter or receiver can’t support the video thumbnail feature.</p>
	<p>Displayed when a transmitter’s source streams are collectively over the bandwidth limitation of 10Gbps.</p>
 <p>OFFLINE</p>	<p>Displayed when a transmitter or receiver is offline or not currently detected by the IP Master Controller.</p>

- 2) **Video Wall Routing:** Provides drag-and-drop source selection for pre-defined video wall groups.

Note: Video wall groups are defined within the Video Wall tab, please see section 6.6.7 for more information.

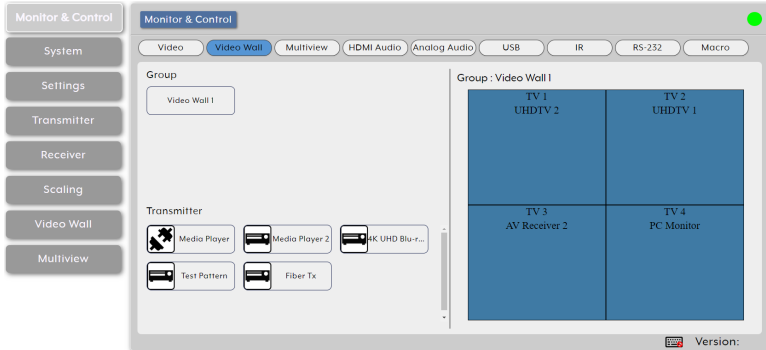

- **Group:** All currently defined video wall groups will be listed under the “Group” heading. Clicking on a group’s icon will display a simplified graphical representation of the video wall on the right side of the page in the Group View.
- **Transmitter:** All sources will be listed under the “Transmitter” heading. To assign a source to a video wall group, drag the transmitter to the preferred group.

Note: Dragging a source to a previously inactive video wall group will automatically activate the video wall on all associated displays.

- **Group View:** Shows a simplified graphical representation of the currently selected video wall group. If the video wall is active the windows will be green and display a faded video thumbnail of the currently selected source. If one or more of the displays in the group is not currently active, those windows will be blue.

- 3) **Multiview Selection:** Provides drag-and-drop output selection and window source selection for pre-defined multiviewer presets.

Note: Multiviewer presets are defined within the Multiviewer tab, please see section 6.6.8 for more information.



- **Preset:** All currently defined multiviewer presets will be listed under the “Preset” heading. To display a multiviewer preset on a specific output, drag the preset onto the preferred receiver.
- **Receiver:** All displays will be listed under the “Receiver” heading. Clicking on a display that currently has a multiviewer preset assigned to it will display a simplified graphical representation of the preset on the right side of the page in the Multiviewer View.
- **Multiviewer View:** Shows a simplified graphical representation of the currently selected multiviewer preset. If the preset is active the windows will be green and display a faded video thumbnail of each window’s currently selected source.
- **Transmitter:** All sources are listed here with any currently unavailable sources displayed in red. To assign a new source to an existing multiview layout’s window, drag the source to the preferred window within the Multiviewer View.

Note: A single source cannot be simultaneously displayed in differently sized windows or in multiple presets at different output resolutions.

- 4) **HDMI Audio Routing:** Provides drag-and-drop control over the independent HDMI audio routing of all detected transmitters and receivers.

Note: Bitstream audio is only supported when the receiver's HDMI audio device setting is set to "HDMI Audio (Follow Video in Genlock Mode)".

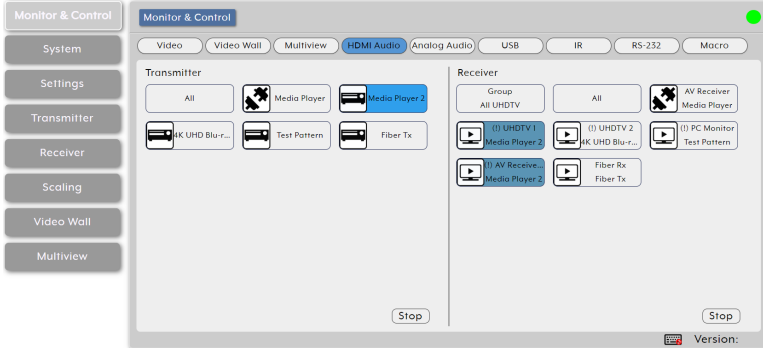

- **HDMI Audio Transmitter:** This section provides drag-and-drop buttons for all transmitters detected by the system as well as a button target to stop one or all independent HDMI audio streams from being transmitted.

Source to Single Receiver Routing: To route an HDMI audio source to a receiver, click and drag the source's button on the left to the preferred display on the right side, then release the mouse button. If the routing was completed successfully, the newly routed source's name will appear below the display's name within the button. Clicking on any source button will change the color of itself, and all currently routed displays.

Note: Receivers may also be drag and dropped onto sources to activate a new route.

Source to Multiple Receiver Routing: To route an HDMI audio source to multiple receivers at the same time, click and drag the source's button on the left to a Group button or the "All" button on the right side, then release the mouse button. If the routing was completed successfully, the source's name will appear within all appropriate buttons.

Stop Stream: To stop the independent HDMI audio stream from a single source, drag the source down to the "Stop" button at the bottom of the window, then release the mouse button. To stop ALL

independent HDMI audio streams, drag the “All” button down to the “Stop” button.

Note: When a receiver’s HDMI Audio is set to “Follow Video in Genlock Mode”, and scaling on that output has been disabled (Bypass), the audio output on that receiver cannot be stopped by using this control.

- **HDMI Audio Receiver:** This section provides drag-and-drop buttons for all receivers detected by the system as well as a button target to stop one or all independent HDMI audio streams.

Note: When a receiver’s HDMI Audio is set to “Follow Video in Genlock Mode” and scaling on that output has been disabled (Bypass), the HDMI audio routing selection is ignored and the audio embedded with the HDMI source will always be output. In these instances a (!) mark will be displayed.

Stop Stream: To stop the HDMI audio stream on a single display, drag the display down to the “Stop” button at the bottom of the window, then release the mouse button. To stop HDMI audio on ALL video outputs, drag the “All” button down to the “Stop” button.

Note: When a receiver’s HDMI Audio is set to “Follow Video in Genlock Mode”, and scaling on that output has been disabled (Bypass), the independent audio route will be stopped, however the HDMI embedded audio will continue to be output normally.

- 5) **Analog Audio Routing:** Provides drag-and-drop control over the routing of analog audio input streams between all detected transmitters and receivers.

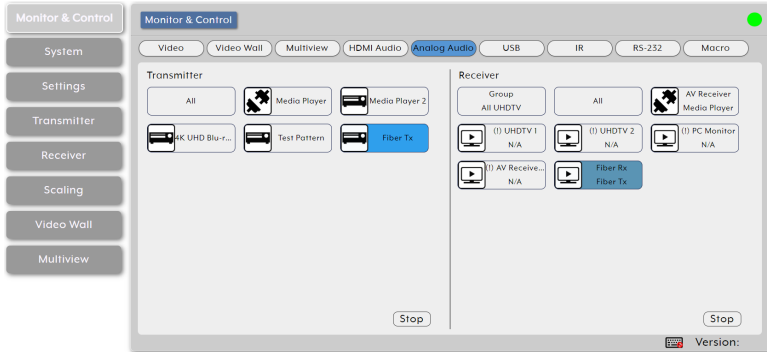

- **Analog Audio Transmitter:** This section provides drag-and-drop buttons for all analog input sources detected by the system as well as a button target to stop one or all analog audio streams from being transmitted.

Source to Single Receiver Routing: To route an analog audio source to a receiver, click and drag the source’s button on the left to the preferred receiver on the right side, then release the mouse button. If the routing was completed successfully, the newly routed source’s name will appear below the receiver’s name within the button. Clicking on any source button will change the color of itself, and all currently routed receivers.

Note: Receivers may also be drag and dropped onto sources to activate a new route.

Source to Multiple Receiver Routing: To route an analog audio source to multiple receivers at the same time, click and drag the source’s button on the left to a Group button or the “All” button on the right side, then release the mouse button. If the routing was completed successfully, the source’s name will appear within all appropriate buttons.

Stop Stream: To stop the analog audio stream from a single source, drag the source down to the “Stop” button at the bottom of the window, then release the mouse button. To stop ALL analog audio streams, drag the “All” button down to the “Stop” button.

- Analog Audio Receiver:** This section provides drag-and-drop buttons for all analog audio outputs detected by the system as well as a button target to stop the output of one or all analog audio streams.

Note: If the selected audio source for an analog output has been set to “HDMI Audio (Stereo Downmix)” that output will be marked with a (!) and the audio output will mirror the source set on the HDMI Audio routing page.

Stop Stream: To stop the analog audio output on a single receiver, drag the receiver down to the “Stop” button at the bottom of the window, then release the mouse button. To stop ALL video outputs, drag the “All” button down to the “Stop” button.

Note: If the selected audio source for an analog output has been set to “HDMI Audio (Stereo Downmix)” the audio output can only be stopped from the HDMI Audio page.

- USB Pairing:** Provides drag-and-drop control over the pairing of USB hosts (PC, laptop, etc.) and USB devices (keyboard, mouse, webcam, etc.) between the ports detected on all transmitters and receivers.

Note: When a USB host port has enabled “Simultaneous Mode”, it can be paired with up to 7 device endpoints. If “Simultaneous Mode” is disabled, a USB host port can only be paired with a single USB device endpoint.

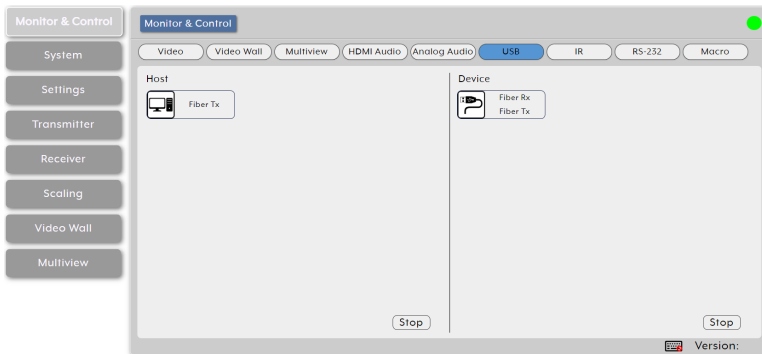

- USB Host:** This section provides drag-and-drop buttons for detected USB host ports as well as a button target to stop communication from a host.

Host to Device Pairing: To pair a USB host with a USB device, click and drag the USB host's button on the left to the preferred USB device on the right side, then release the mouse button. If the pairing was completed successfully, the active USB host's name will appear below the USB device's name within the button. Clicking on any USB host button will change the color of itself, and all currently paired USB device endpoints.

Note: USB devices may also be drag and dropped onto USB hosts to activate a new pairing.

Stop Host: To stop communication from a USB host, drag the USB host down to the "Stop" button at the bottom of the window, then release the mouse button.

- **USB Device:** This section provides drag-and-drop buttons for all detected USB device endpoints as well as a button target to stop communication from a device.

Stop Device: To stop communication from a USB device, drag the USB device down to the "Stop" button at the bottom of the window, then release the mouse button.

- 7) **IR Routing:** Provides drag-and-drop control over the routing of the IR inputs and outputs detected on all transmitters and receivers.

Note: An IR output can be routed to by multiple IR inputs, however each IR input may only be directly routed to a single IR output. If an IR input needs to be sent to more than one output, the Global Broadcast option must be used.

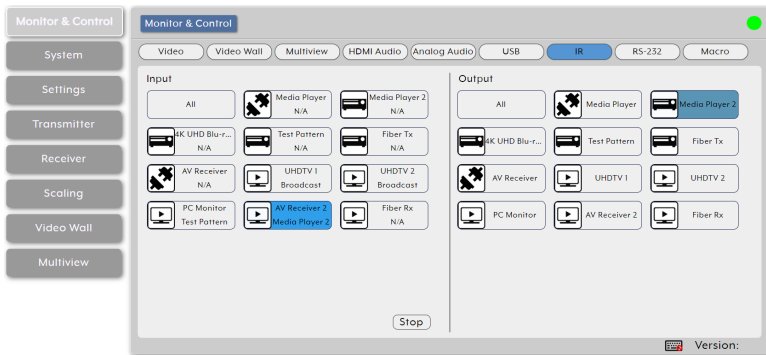

- **IR Input:** This section provides drag-and-drop buttons for all IR input ports detected by the system as well as a button target to stop one or all IR streams from being transmitted.

IR Input Global Broadcast: To broadcast an IR input to all available IR outputs, click and drag the IR input's button on the left to the "All" button on the right side, then release the mouse button. If the routing was completed successfully, the word "Broadcast" will appear within the appropriate IR input's button.

Stop Stream: To stop the broadcast of an IR signal from a single IR input, drag the IR input down to the "Stop" button at the bottom of the window, then release the mouse button. To stop the transmission of ALL IR signals, drag the "All" button down to the "Stop" button.

- **IR Output:** This section provides drag-and-drop buttons for all IR output ports detected by the system.

IR Output to IR Input Routing: To connect an IR output to an IR input, click and drag the IR output's button on the right to the preferred IR input on the left side, then release the mouse button. If the routing was completed successfully, the newly routed IR output's name will appear below the IR input's name within its button. Clicking on any IR output button will change the color of itself, and all IR inputs currently routed to it.

Note: IR inputs may also be drag and dropped onto IR outputs to activate a new route.

- 8) **RS-232 Routing:** Provides drag-and-drop control over the routing of the RS-232 senders and receivers detected on all transmitters and receivers. The RS-232 port on a standard extension unit contains one sender (Rx pin) and one receiver (Tx pin).

Note: An RS-232 receiver can be routed to by multiple RS-232 senders, however each RS-232 sender may only be directly routed to a single RS-232 receiver. If an RS-232 sender needs to be sent to more than one receiver, the Global Broadcast option must be used.

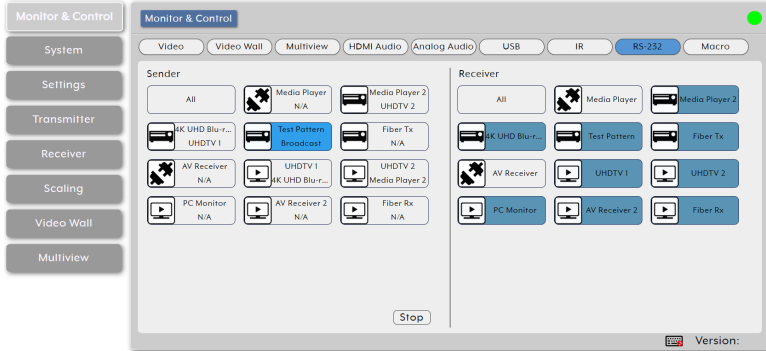

- **RS-232 Sender:** This section provides drag-and-drop buttons for all RS-232 senders detected by the system as well as a button target to stop one or all RS-232 streams from being transmitted.

RS-232 Sender Global Broadcast: To broadcast an RS-232 sender to all available RS-232 receivers, click and drag the RS-232 sender's button on the left to the "All" button on the right side, then release the mouse button. If the routing was completed successfully, the word "Broadcast" will appear within the appropriate RS-232 sender's button.

Stop Stream: To stop the broadcast of an RS-232 signal from a single RS-232 sender, drag the RS-232 sender down to the "Stop" button at the bottom of the window, then release the mouse button. To stop the transmission of ALL RS-232 signals, drag the "All" button down to the "Stop" button.

- **RS-232 Receiver:** This section provides drag-and-drop buttons for all RS-232 receivers detected by the system.

RS-232 Receiver to RS-232 Sender Routing: To connect an RS-232 receiver to an RS-232 sender, click and drag the RS-232 receiver's button on the right to the preferred RS-232 sender on the left side, then release the mouse button. If the routing was completed

successfully, the newly routed RS-232 receiver's name will appear below the RS-232 sender's name within its button. Clicking on any RS-232 receiver button will change the color of itself, and all RS-232 senders currently routed to it.

Note: RS-232 senders may also be drag and dropped onto RS-232 receivers to activate a new route.

- 9) **Macro Activation:** Provides a simple interface to activate macros that have been pre-defined and stored within the IP Master Controller

Note: Only one macro can be executed at a time.

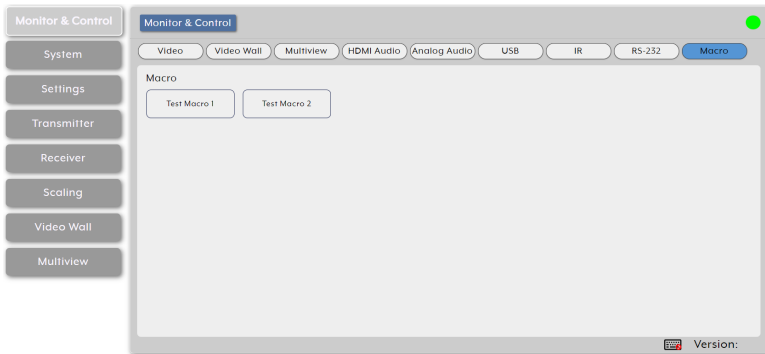

- **Macro:** All available macros will be listed in this section. To activate a macro, simply click on its button. The button will remain blue until the macro has completed executing.

6.6.2 System Tab

This tab provides access to system configuration options including IP configuration for both LAN ports, interface language, login and user management, and firmware update functionality.

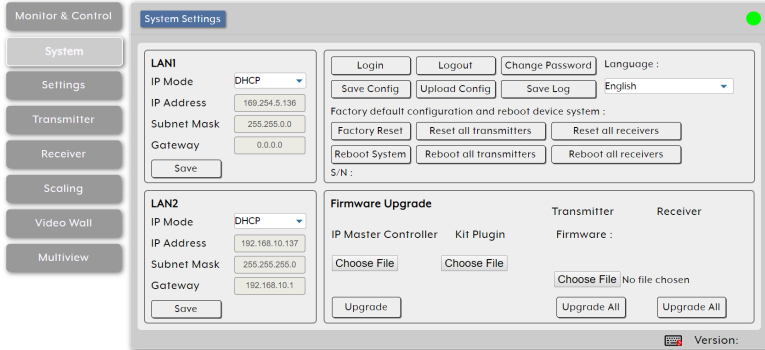

- 1) **LAN 1 & LAN 2:** The IP mode for each LAN port (DHCP or Static IP), IP address, netmask, and gateway can be set here. When a LAN port is set to “DHCP” mode, it will automatically attempt to obtain proper configuration information from the local DHCP server. If no DHCP server is available, it will automatically assign itself an APIPA address from the 169.254.xxx.xxx range. To configure the network settings manually, please set the LAN port to “Static IP” mode and enter the information as appropriate for the connected network. Press “Save” to activate the changes.

Note: Both LAN ports default to “DHCP” mode. The current IP address can be verified using the HDMI output or RS-232 if the Device Discovery software is not available.

- 2) **System Commands:**

- **Login/Logout:** Click these buttons to log into or out of the WebGUI interface.

Note: When not logged in, only the “Monitor & Control” and “System” tabs are available.

- **Change Password:** Click this button to change the WebGUI’s administrator login password.
- **Language:** Use this dropdown to select the preferred display language for the unit’s WebGUI interface.

- **Save Config:** The current system configuration may be saved as a *.bin file to the local PC. Click the “Save Config” button to save the current system configuration to your local PC.
- **Upload Config:** The system configuration may be restored from a previously saved *.bin file. Click the “Choose File” button to locate the saved *.bin file, then click the “Open” button.
- **Save Log:** A comprehensive system log file to help diagnose configuration issues or other problems can be generated, if requested by technical support. Click the “Save Log” button to save a copy of the current log data in, *.zip format, to your local PC.

Note: The generated file is password protected and is only intended for use by authorized technical support.

- **Factory Reset:** Resets the unit back to its factory default settings.

Note: This Factory Reset does NOT clear the transmitter and receiver history tables. To completely remove old transmitter and receiver units from the system, use the “Remove” option on the Transmitter and Receiver tabs.

- **Reset all transmitters/receivers:** Reset all detected transmitters or all detected receivers back to their factory default settings.
- **Reboot System:** Reboot this unit.
- **Reboot all transmitters/receivers:** Reboot all detected transmitters or all detected receivers.
- **S/N:** Displays the unit’s serial number.

- 3) **Firmware Upgrade:** Provides a method to remotely update the firmware of this unit as well as to update the firmware of detected transmitters and receivers.

Note: The update process can take several minutes to complete, especially if there are a large number transmitters and receivers in the system. Please do not power off any units during the update process.

- **IP Master Controller Firmware:** To update the unit’s firmware click the “Choose File” button to open the file selection window and then select an appropriate firmware update file (*.bin format) located on your local PC. After selecting the file, click the “Upgrade” button to begin the firmware update process. Once the firmware update process has completed the unit will reboot.

- **Kit Plugin:** Provides a way to upgrade the system with additional, optional, plugins. To upload a new plugin, click the “Choose File” button to locate the appropriate file on your local PC, then click the “Open” button.
- **Transmitter/Receiver Firmware:** To update the firmware of all detected transmitters or receivers, click the “Choose File” button to open the file selection window and then select an appropriate firmware update file (*.apz format) located on your local PC. After selecting the file, click the appropriate “Upgrade All” button to begin the firmware update process on all transmitters, or receivers. Once the firmware update process has completed the appropriate units will reboot.

Note: The transmitter/receiver firmware is stored within the IP Master Controller after upload and will also be used when performing individual unit updates within the Transmitter and Receiver tabs.

6.6.3 Settings Tab

This tab provides control over the configuration of a variety of the unit's different internal systems and interfaces including group and macro creation, manual IR and RS-232 command broadcasting, I/O trigger assignment, EDID management, and setting the system's clock and event scheduling.

- 1) **Group:** This section provides a way to collect multiple receiving endpoints into single groups to be used as simple, single click, targets for routing A/V, USB or IR/RS-232 sources. Once created, each group will appear within the appropriate section of the Monitor & Control tab along with standard receivers.

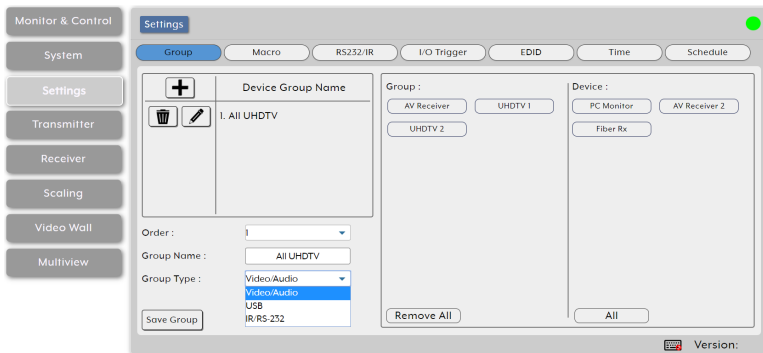

- **Device Group List:** The upper-left section contains a list of all currently defined groups and provides a way to create new groups, edit them, or delete them. To add a new group, click on the “Add” icon (+) and then select the preferred options and endpoints. To edit an existing group, click on the “Edit” icon (✎) and then make whatever changes are required. Once a new or edited group has been configured, click on the “Save Group” button at the bottom of the page to store the group. To delete an existing group, click on the “Delete” icon (🗑️) next to the appropriate group name.

Note: Leaving this screen before selecting “Save Group” will undo any changes made.

- **Order:** Use the dropdown to select the position within the group list for the currently selected group.

Note: The order in the list also impacts the order groups are displayed within the Monitor & Control tab.

- **Group Name:** Type the preferred name for the currently selected group.
 - **Group Type:** Select the media type contained within this group. Options are: Video/Audio, USB, and IR/RS-232. This selection will determine the type of receiver endpoints available within the Device List.
 - **Group List:** This section contains all of the receiving endpoints that are assigned to the currently selected group. Clicking on an endpoint will remove it from the group and place it back in the “Device” section. To remove all devices from the current group, click on the “Remove All” button.
 - **Device List:** This section contains all of the available receiving endpoints for use in the currently selected group type. Clicking on an endpoint will move it into the “Group” section and add it to the group. To add all available receiver endpoints to the group, click on the “All” button.
- 2) **Macro:** This section provides a way to create operational command sequences that can be activated via the IR remote control, external triggers, or from within the WebGUI. Macros are a flexible and powerful tool. They can be as simple as selecting a new input for a receiver or a complex sequence of source, resolution, mode and audio changes executed in sequence. Up to 16 macros can be defined, and each macro can contain up to 64 commands.

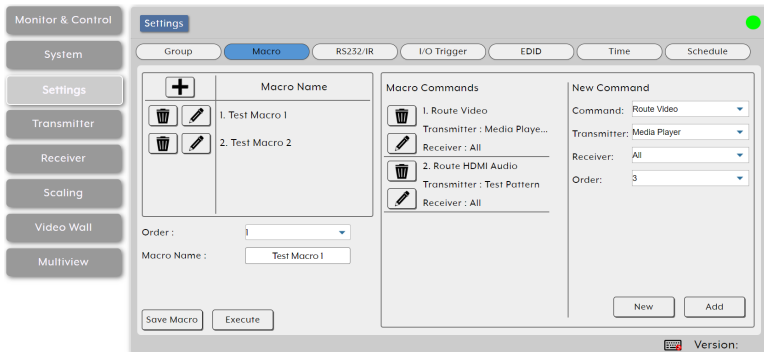

- **Macro List:** The upper-left section contains a list of all currently defined macros and provides a way to create new macros, edit them, or delete them. To add a new macro, click on the “Add” icon (+) and then create/add new commands for it in the window to the right. To

edit an existing macro, click on the “Edit” icon (✎) and then make whatever changes are required. Once a new or edited macro has been configured, click on the “Save Macro” button at the bottom of the page to store the macro. To delete an existing macro, click on the “Delete” icon (🗑) next to the appropriate macro name. To immediately test the execution behavior of the currently selected macro, click the “Execute” button.

Note: Leaving this screen before selecting “Save Macro” will undo any changes made.

- **Order:** Use the dropdown to select the position within the macro list for the currently selected macro.

Note: The order in the list also impacts the order macros are listed within the Monitor & Control tab and when assigning IR/trigger functionality.

- **Macro Name:** Type the preferred name of the currently selected macro.

- **Macro Command List:** This section contains a list of all currently assigned commands within the macro and their execution order. To edit an existing command, click on the “Edit” icon (✎) and then make whatever changes are required in the right-hand panel. To create a new macro command, click on the “New” button at the bottom right side of the window and then configure it as preferred in the right-hand panel. Once a command has been edited, click on the “Confirm/Add” button at the bottom of the page to store the command in the macro. To delete an existing command, click on the “Delete” icon (🗑) next to the appropriate command.

Note: Clicking on “Confirm” or “Add” only stores the current changes to the command list of the macro currently being edited. The entire macro still needs to be saved by using the “Save Macro”. Leaving this screen before selecting “Save Macro” will undo any changes made.

- **New/Edit Command Details:** This section contains the details of the command currently being edited or created.
 - **Command:** Use the dropdown to select from the available macro command types.
 - **Object 1 (contextual):** Use the dropdown to select the first component this command will affect. Typically this will be a transmitter, but the objects listed depend upon the specific requirements of the selected command.

- **Object 2 (contextual):** Use the dropdown to select the second component this command will affect. Typically this will be a receiver, but the objects listed depend upon the specific requirements of the selected command.
 - **Order:** Use the dropdown to select this command's position within the command list for the currently selected macro.
- 3) **RS232/IR:** This section provides a way to manually send individual RS-232 or IR commands to specific receiver endpoints within the current system.

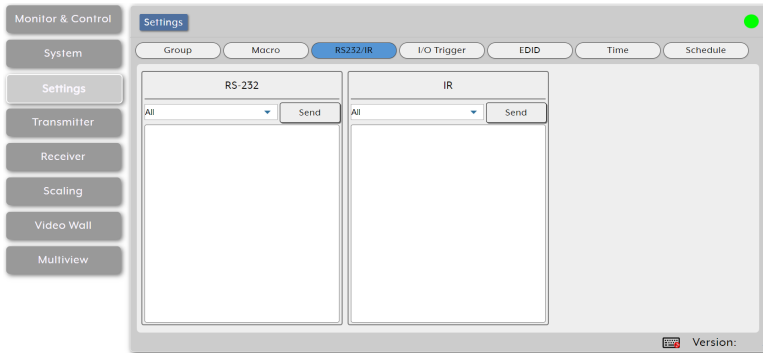

- **RS-232:** To send an RS-232 command, use the dropdown to select the target endpoint, type or paste the command into the space provided, and then click “Send” to transmit the command immediately.
Note: To transmit hex data, each ASCII hex pair (octet) must be preceded by “\x”. For example a carriage return would be “\x0D”.
 - **IR:** To send an IR command, use the dropdown to select the target endpoint, type or paste a pronto hex code into the space provided, and then click “Send” to transmit the command immediately.
- 4) **I/O Trigger:** This section provides a way to assign macros to each of the 8 trigger inputs on the unit as well as to the 8 IR remote buttons.

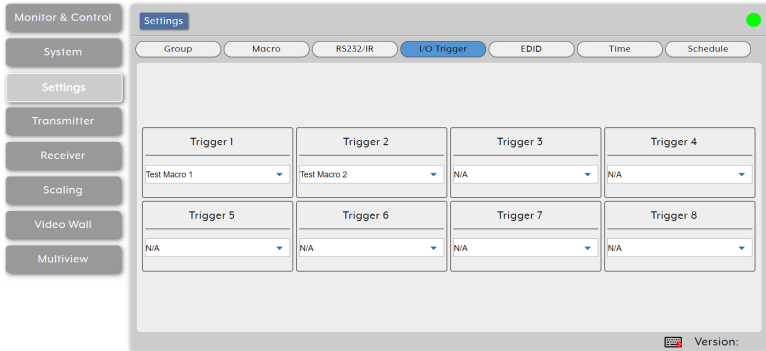

- **Trigger 1~8:** use the dropdowns to select the macro to assign to each trigger pin on the unit.

Note: The IR remote button number assignments will match the trigger assignments.

- 5) **EDID:** This section provides a way to manage and assign EDID to any or all of the available transmitters. EDIDs may be assigned from a selection of 6 built in default EDIDs, the displays connected to any receiver, or from a user uploaded EDID.

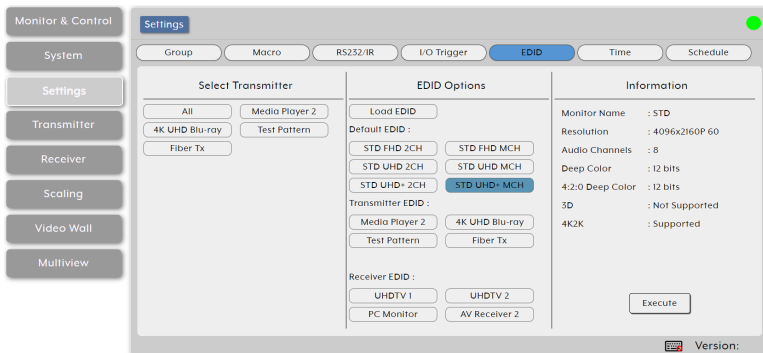

- **Select Transmitter:** This section contains a list of all currently available transmitters as well as an “All” button. Click on one or more transmitters to select them as the target for EDID assignment.
- **EDID Options:** This section displays a list of all currently available EDID sources.

Note: In most cases, assigning a new EDID to an input will cause the affected input to briefly blink out while the source adapts to the new information.

- **Load EDID:** To update the EDID of one or more transmitters with a previously saved User EDID, click the “Load EDID” button to open the file selection window and then select the EDID file (*.bin format) located on your local PC. After selecting the file, click the “Open” button to copy the EDID to the IP Master Controller. After the EDID has been loaded, the details will be displayed in the Information window. Select the transmitter(s) to copy the EDID to, and then click the “Execute” button in the bottom right window.
- **Default EDID:** Lists the 6 available default EDIDs that are included with the unit. To copy one of these EDIDs to one or more transmitters, select the preferred EDID and then select the transmitter(s) to copy the EDID to. Click the “Execute” button in the bottom right window to finalize the assignment.

This unit provides the following 6 default EDIDs:

Unit's Default EDIDs	
STD FHD 2CH	1920×1080p@60Hz (4.95Gbps) & 8-bit color, LPCM 2.0
STD FHD MCH	1920×1080p@60Hz (4.95Gbps) & 8-bit color, LPCM 7.1 & Bitstream
STD UHD 2CH	3840×2160p@30Hz (10.2Gbps) & Deep Color (8/10/12-bit), LPCM 2.0
STD UHD MCH	3840×2160p@30Hz (10.2Gbps) & Deep Color (8/10/12-bit), LPCM 7.1 & Bitstream
STD UHD+ 2CH	3840×2160p@60Hz (18Gbps) & Deep Color (8/10/12-bit), LPCM 2.0
STD UHD+ MCH	3840×2160p@60Hz (18Gbps) & Deep Color (8/10/12-bit), LPCM 7.1 & Bitstream

Note: In some rare cases it is possible for custom or external EDIDs to cause compatibility issues with certain sources. If this happens, it is recommended to switch to one of the 7 default EDIDs for maximum compatibility.

- **Transmitter EDID:** Lists all available transmitters. To copy the EDID from one of these transmitters to one or more additional transmitters, select the preferred transmitter's EDID from this list and then select the transmitter(s) in the window on the left to copy the EDID to. Click the "Execute" button in the bottom right window to finalize the assignment.
- **Receiver EDID:** Lists all available receivers. To copy the EDID from the display attached to one of these receivers to one or more transmitters, select the preferred receiver's EDID from this list and then select the transmitter(s) in the window on the left to copy the EDID to. Click the "Execute" button in the bottom right window to finalize the assignment.

Note: Selecting any EDID source from the EDID Options section will display the current details in the Information window.

- **Information:** This window shows basic detail information about the currently selected EDID.
- **Execute:** Click this button to assign the EDID currently displayed in the Information window to all currently selected transmitters.

- 6) **Time:** This section provides a way to automatically set and sync the unit's system clock using a standard internet NTP (Network Time Protocol) server.

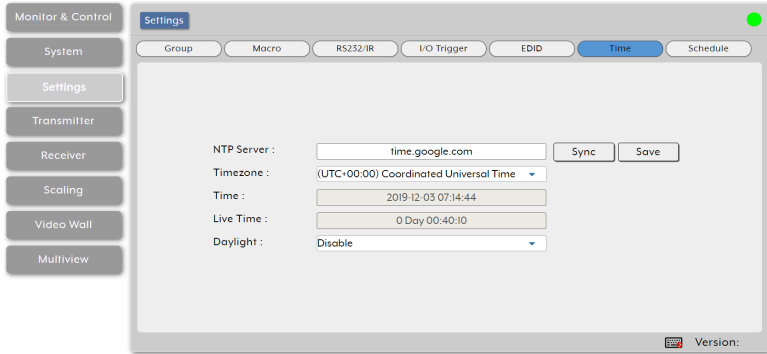

- **NTP Server:** Enter the hostname or IP address of the preferred NTP server to use for time synchronization. After changing the NTP server, click the “Save” button to store the new information. Click the “Sync” button to force the unit to sync to the NTP server immediately.

Note: This unit's clock does not have a battery backup, so time is not kept if the unit is unplugged. However, the time will automatically sync at power up as long as an internet connection is available and the NTP server is valid.

- **Timezone:** Use the dropdown to select your local time zone.
- **Time:** Shows the unit's current time.
- **Live Time:** Shows the length of time the unit has been online since the last reboot.
- **Daylight:** Enable or disable support for daylight savings time.

7) **Schedule:** This section provides access to the settings and controls for configuring scheduled execution of macros. A macro can be scheduled to execute once at a specific time and date, on a periodic rotation, or at set times on specific days of the week.

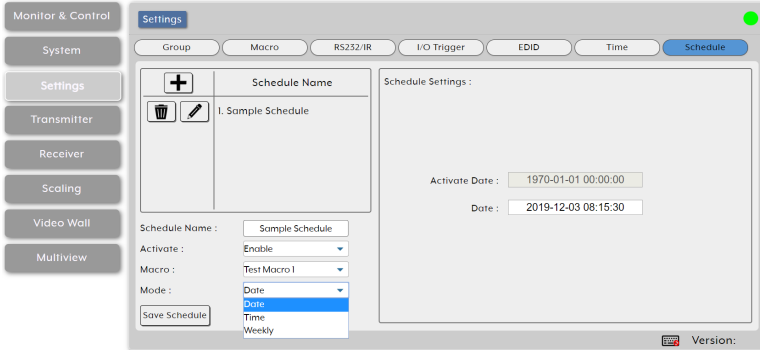

- **Schedule List:** The upper-left section contains a list of all currently defined schedule events and provides a way to create new schedule events, edit them, or delete them. To add a new schedule event, click on the “Add” icon (+) and then select the preferred options. To edit an existing schedule event, click on the “Edit” icon (✍) and then make whatever changes are required. Once a new or edited schedule has been configured, click on the “Save Schedule” button at the bottom of the page to store the schedule event. To delete an existing schedule event, click on the “Delete” icon (🗑) next to the appropriate schedule event name.

Note: Leaving this screen before selecting “Save Schedule” will undo any changes made.

- **Schedule Name:** Enter the preferred name for the current schedule event.
- **Activate:** Use the dropdown to enable or disable the current schedule event.
- **Macro:** Use the dropdown to select the macro to activate at the scheduled time.
- **Mode:** Used the dropdown to select the scheduling style for the current schedule event.

- **Date:** Select “Date” to execute the selected macro a single time on a specified day. After the configuration is complete, click on the “Save Schedule” button at the bottom of the page to store the schedule event.

Activate Date :

Date :

Activate Date: Clicking on the date field will open the calendar entry window. Select the preferred day and time and then click “Done”. Clicking the “Now” button will jump the entry field to the current time.

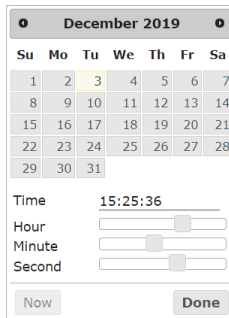

December 2019

Su	Mo	Tu	We	Th	Fr	Sa
1	2	3	4	5	6	7
8	9	10	11	12	13	14
15	16	17	18	19	20	21
22	23	24	25	26	27	28
29	30	31				

Time

Hour

Minute

Second

- **Time:** Select “Time” to execute the selected macro on a regularly timed schedule starting at a specified time on a specified day. After the configuration is complete, click on the “Save Schedule” button at the bottom of the page to store the schedule event.

Activate Date :

Time Interval : Day

Times :

0 is unlimited, 1~N is times

Activate Date: The activate date is the date and time of the first execution of the macro. Clicking on the date field will open the calendar entry window. Select the preferred day and time and then click “Done”. Clicking the “Now” button will jump the entry field to the current time.

Time Interval: Enter the length of time to wait between executions of the macro in days, hours, minutes and seconds. Clicking on the time field will open the “Choose Time” window to make setting a time easier.

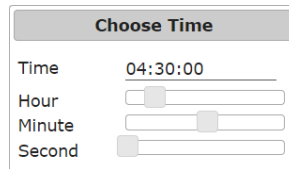

The "Choose Time" dialog box has a title bar "Choose Time". It contains four rows of controls: "Time" with a text input field showing "04:30:00"; "Hour" with a slider control; "Minute" with a slider control; and "Second" with a slider control.

Times: Enter the number of times the schedule event should repeat. Entering “0” will make the event continually repeat.

- **Weekly:** Select “Weekly” to execute the selected macro at a specific time on set days of the week. After the configuration is complete, click on the “Save Schedule” button at the bottom of the page to store the schedule event.

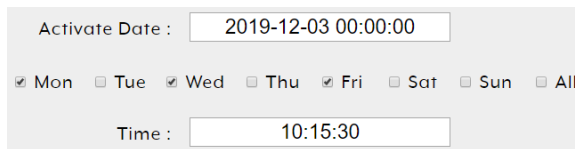

The form shows "Activate Date :" with a text input field containing "2019-12-03 00:00:00". Below it are seven checkboxes for days of the week: Mon, Tue, Wed, Thu, Fri, Sat, Sun, and All. At the bottom, "Time :" is followed by a text input field containing "10:15:30".

Activate Date: The activate date is the date and time of the first execution of the macro. Clicking on the date field will open the calendar entry window. Select the preferred day and time and then click “Done”. Clicking the “Now” button will jump the entry field to the current time.

Day Selection: Select which days of the week the macro should execute on.

Time: Enter the time to execute the macro on all selected days. Clicking on the time field will open the “Choose Time” window to make setting a time easier.

- **Save Schedule:** Click this button to save changes to the current schedule.

6.6.4 Transmitter Tab

This tab shows all transmitters that have been detected by the unit. Details about each transmitter's name, IP address, and video content, as well as options to configure the network, RS-232, USB, and general device settings are also provided.

Note: Units that were previously a part of the system, but are not currently detected will still be displayed, however they will have a disconnected icon (🔌) and cannot be used for routing. These units may be removed from the list using the "Remove" button.

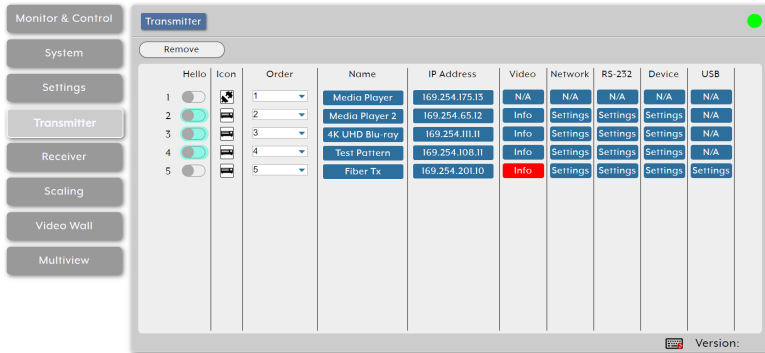

1	2	3	4	5					
<input type="checkbox"/>		1	Media Player	169.254.175.15	N/A	N/A	N/A	N/A	N/A
<input type="checkbox"/>		2	Media Player 2	169.254.65.12	Info	Settings	Settings	Settings	N/A
<input type="checkbox"/>		3	4K UHD Blu-ray	169.254.111.11	Info	Settings	Settings	Settings	N/A
<input type="checkbox"/>		4	Test Pattern	169.254.100.11	Info	Settings	Settings	Settings	N/A
<input type="checkbox"/>		5	Fiber Tx	169.254.201.10	Info	Settings	Settings	Settings	Settings

1) Transmitter Configuration:

- Remove:** Click on this button to remove any transmitter from the list that has the disconnected icon (🔌). The pop-up window provides a dropdown to select the unit to be removed. Once the selection has been made, click on "Confirm" to apply the change.

Note: Only disconnected transmitters can be removed.

- Hello:** Clicking on this switch will cause the selected unit to immediately begin flashing the power LED on the front of the unit to make it easy to find. Clicking it a second time returns the LED to its normal behavior.

Note: The "Hello" function is not supported by all SDVoE units. Units that support this function will have the switch highlighted.

- Icon:** Displays the icon used to represent the unit.

Note: If a transmitter's streams require more bandwidth than is available, a warning icon (⚠️) will be displayed instead of the normal source icon. Video output from a source displaying this icon may

become visually unstable. It is recommended to either lower the resolution or framerate of the stream.

- **Order:** Use the dropdown to reorder the units in the list. Changing the order here will also change the order the units are listed in other tabs.

- **Name:** Displays each unit's current assigned name.

Note: The name can be changed within "Device Settings".

- **IP Address:** Displays each unit's current IP address.

- **Video Info:** Clicking this button will display a pop-up window containing detailed information about the current video source.

Note: If no live source is detected the button will turn red.

- **Network Settings:** Clicking this button will display a pop-up window containing detailed information about the unit's current network settings, including IP mode, and allow for those settings to be changed. To activate any changes made, please click on the "Save" button to close the window.

- **RS-232 Settings:** Clicking this button will display a pop-up window containing detailed information about the unit's current RS-232 settings, including baud rate, and allow for those settings to be changed. To activate any changes made, please click on the "Save" button to close the window.

- **Device Settings:** Provides controls over a number of unit-specific functions. See below for more detail.

- **USB Settings:** Clicking this button will display a pop-up window containing detailed information about the unit's current USB settings, including enabling or disabling simultaneous mode support. To activate any changes made, please click on the "Save" button to close the window.

Note: USB functionality is not supported by all SDVoE units.

- 2) **Device Settings:** Clicking this button will display a pop-up window providing control over a number of important device settings and allow for those settings to be changed. To activate any changes made, please click on the “Save” button to close the window.

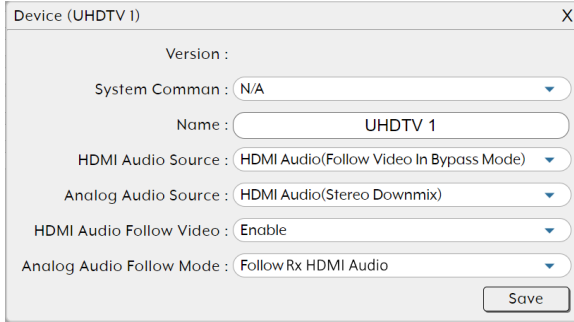

- **Version:** Display the unit’s current firmware version.
- **System Command:** Use the dropdown to select a system command to send to the unit. Typically available commands are:
 - **Factory Reset:** Reset the unit back to its factory default settings.
 - **Reboot:** Reboot the unit.
 - **Firmware Update:** Update the firmware of this unit using the currently uploaded firmware file.
 - **Transform (Transceivers only):** Switch the unit into receiver mode.
- **Name:** Change the unit’s name (19 character maximum).
- **Audio Port Direction:** Define the analog audio port as an input or output.
- **HDCP Support:** Enable or disable support for HDCP 1.4 or lower sources.
- **HDCP 2.2 Support:** Enable or disable support for HDCP 2.2 sources.
- **Bypass Divide FPS by two:** Enable or disable the Divide FPS (Frames Per Second) by Two feature on the primary video stream generated by this unit. Enabling this mode will cut bandwidth usage of the unit nearly in half at the cost of a 50% framerate reduction.

Note: When this mode is enabled, it is not recommended to use Bypass Mode from the scaling tab as most displays cannot properly handle the resulting output.

- **Multiview Divide FPS by two:** Enable or disable the Divide FPS (Frames Per Second) by Two feature on the secondary video stream generated by this unit which is used in Multiviewer mode. Enabling this mode will reduce bandwidth usage of the unit somewhat but only when Multiviewer mode has been activated.

6.6.5 Receiver Tab

This tab shows all receivers that have been detected by the unit. Details about each receiver's name, IP address, and video content, as well as options to configure the network, RS-232, USB and general device settings are also provided.

Note: Units that were previously a part of the system, but are not currently detected will still be displayed, however they will have a disconnected icon (🔌) and cannot be used for routing. These units may be removed from the list using the "Remove" button.

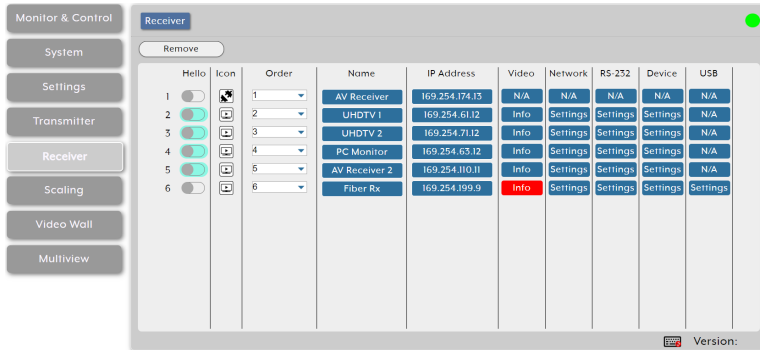

1	2	3	4	5	6				
<input type="checkbox"/>	🔌	1	AV Receiver	169.254.174.13	N/A	N/A	N/A	N/A	N/A
<input checked="" type="checkbox"/>	📺	2	UHDTV 1	169.254.61.12	Info	Settings	Settings	Settings	N/A
<input checked="" type="checkbox"/>	📺	3	UHDTV 2	169.254.71.12	Info	Settings	Settings	Settings	N/A
<input checked="" type="checkbox"/>	📺	4	PC Monitor	169.254.65.12	Info	Settings	Settings	Settings	N/A
<input checked="" type="checkbox"/>	📺	5	AV Receiver 2	169.254.110.11	Info	Settings	Settings	Settings	N/A
<input type="checkbox"/>	🔌	6	Fiber Rx	169.254.199.9	Info	Settings	Settings	Settings	Settings

1) Receiver Configuration:

- Remove:** Click on this button to remove any receiver from the list that has the disconnected icon (🔌). The pop-up window provides a dropdown to select the unit to be removed. Once the selection has been made, click on "Confirm" to apply the change.

Note: Only disconnected receivers can be removed.

- Hello:** Clicking on this switch will cause the selected unit to immediately begin flashing the power LED on the front of the unit to make it easy to find. Clicking it a second time returns the LED to its normal behavior.

Note: The "Hello" function is not supported by all SDVoE units. Units that support this function will have the switch highlighted.

- Icon:** Displays the icon used to represent the unit.
- Order:** Use the dropdown to reorder the units in the list. Changing the order here will also change the order the units are listed in other tabs.
- Name:** Displays each unit's current assigned name.

Note: The name can be changed within "Device Settings".

- **IP Address:** Displays each unit's current IP address.
- **Video Info:** Clicking this button will display a pop-up window containing detailed information about the current video output.
Note: If no display is detected the button will turn red.
- **Network Settings:** Clicking this button will display a pop-up window containing detailed information about the unit's current network settings, including IP mode, and allow for those settings to be changed. To activate any changes made, please click on the "Save" button to close the window.
- **RS-232 Settings:** Clicking this button will display a pop-up window containing detailed information about the unit's current RS-232 settings, including baud rate, and allow for those settings to be changed. To activate any changes made, please click on the "Save" button to close the window.
- **Device Settings:** Provides controls over a number of unit-specific functions. See below for more detail.
- **USB Settings:** Clicking this button will display a pop-up window containing detailed information about the unit's current USB settings, including enabling or disabling simultaneous mode support. To activate any changes made, please click on the "Save" button to close the window.

Note: USB functionality is not supported by all SDVoE units.

- 2) **Device Settings:** Clicking this button will display a pop-up window providing control over a number of important device settings and allow for those settings to be changed. To activate any changes made, please click on the “Save” button to close the window.

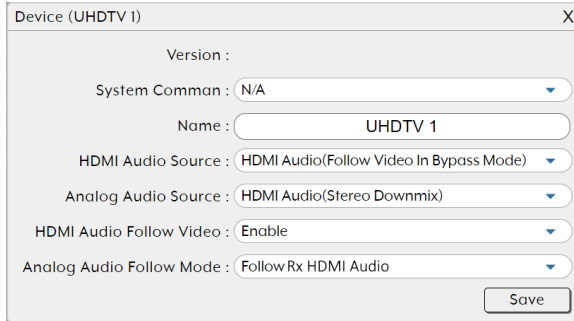

- **Version:** Display the unit’s current firmware version.
- **System Command:** Use the dropdown to select a system command to send to the unit. Typically available commands are:
 - **Factory Reset:** Reset the unit back to its factory default settings.
 - **Reboot:** Reboot the unit.
 - **Firmware Update:** Update the firmware of this unit using the currently uploaded firmware file.
 - **Transform (Transceivers only):** Switch the unit into transmitter mode.
- **Name:** Change the unit’s name (19 character maximum).
- **HDMI Audio Source:** Select the audio source type to embed with the HDMI video output of this unit. Available options are:
 - **HDMI Audio (Follow Video In Bypass Mode):** Output the HDMI audio routed to this unit unless the receiver has been set to “Bypass Mode” in the scaling tab. When “Bypass Mode” is active, only the native HDMI audio from the routed video source can be output.
 - **Analog Audio:** Output the analog audio routed to this unit.
 - **HDMI Audio (Stereo Downmix):** Output the HDMI audio routed to this unit after downmixing it to LPCM 2.0.

Note: This mode only supports HDMI sources with LPCM audio.

- **HDMI Audio (All Channel):** Output the HDMI audio routed to this unit.

Note: This mode only supports HDMI sources with LPCM audio.

- **Analog Audio Source:** Select the audio source type to output from the analog audio output of this unit. Available options are:

- **HDMI Audio (Stereo Downmix):** Output the HDMI audio routed to this unit after downmixing it to stereo.

Note: This mode only supports HDMI sources with LPCM audio.

- **Analog Audio:** Output the analog audio routed to this unit.

- **HDMI Audio Follow Video:** Enable or disable HDMI audio follow video rules for this receiver. When enabled, any HDMI video source switched to this receiver will automatically also route the that transmitter's HDMI audio to this receiver.

Note: This setting overrides any manual routing selections made from the HDMI Audio routing tab.

- **Analog Audio Follow Mode:** Use the dropdown to select the automatic audio follow behavior for this receiver's analog audio output.

- **Disable:** Disables automatic following rules for analog audio on this receiver and allows breakaway audio routing.

- **Follow Rx HDMI Audio:** Analog audio output routing will follow the HDMI audio routing selections made on this receiver.

Note: Selecting this will automatically change the Analog Audio Source type to "HDMI Audio (Stereo Downmix)". This setting overrides any manual routing selections made from the Analog Audio routing tab.

- **Follow Tx Analog Audio:** The analog audio output will automatically use the analog input on the currently routed HDMI video's transmitter.

Note: This setting overrides any manual routing selections made from the Analog Audio routing tab.

6.6.6 Scaling Tab

This tab provides drag-and-drop control over the video output resolution of each receiver in the system.

Note: Due to this scaling occurring only on the receiver side, changes to resolutions here has no impact on bandwidth usage.

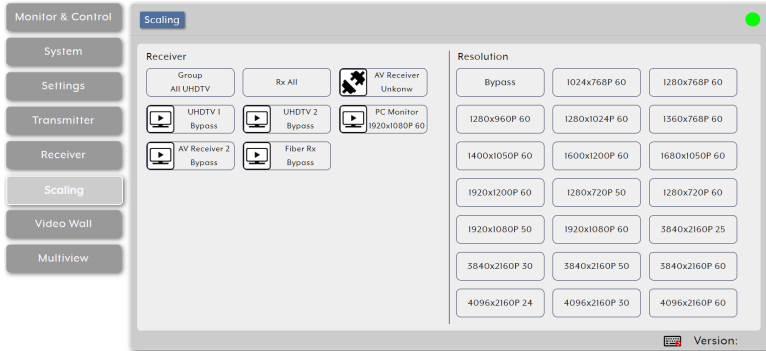

- 1) Resolution Selection:** To select an output resolution for a receiver, click and drag the receiver or receiver group's button on the left to the preferred resolution on the right side, then release the mouse button. If the selection was completed successfully, the new resolution will be displayed below each affected receiver's name. To change all receivers to the same resolution, drag the "Rx All" button to the preferred resolution on the right side. Selecting "Bypass" will force that receiver to output all routed sources in their native resolutions.

Note: Resolutions may also be drag and dropped onto receivers to change the output resolution.

6.6.7 Video Wall Tab

This tab provides a way to configure or modify video walls using multiple receivers in a group. All aspects of the video wall group can be configured here including dimensions (up to 8x8 displays), bezel compensation, display output resolution, and source.

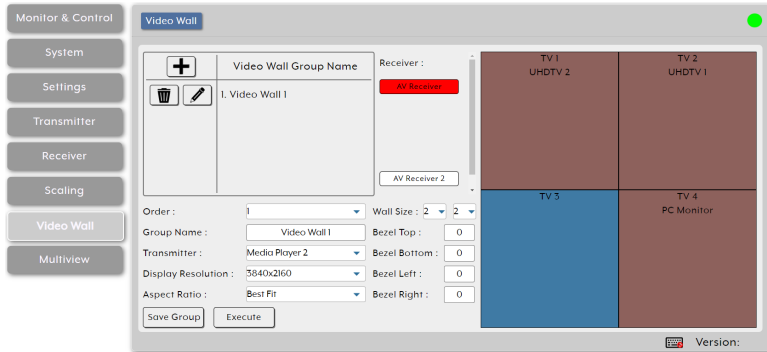

- 1) **Video Wall List:** The upper left section of this tab contains a list of all currently defined video wall groups in the system and provides a way to create new video walls, edit them, or delete them. To add a new video wall, click on the “Add” icon (+) and then select the preferred options and receivers. To edit an existing video wall group, click on the “Edit” icon (✎) and then make whatever changes are required. Once a new or edited video wall group has been configured, click on the “Save Group” button at the bottom of the page to store the group’s configuration. To save and immediately activate the current video wall group, click on the “Execute” button. To delete an existing video wall group, click on the “Delete” icon (🗑️) next to the appropriate group’s name.

Note: Deleting a video wall preset will not disable the video wall it described if it is currently active. To completely remove a video wall, new sources need to be routed to those displays, or the output needs to be disabled from the Monitor & Control Tab.

- **Order:** Use the dropdown to reorder the video wall groups in the list. Changing the order here will also change the order the groups are listed in other tabs.
- **Group Name:** Set the name of the video wall group here.
- **Transmitter:** Select the transmitter to use as the video source for the video wall when the “Execute” button is used.

- **Display Resolution:** Select the resolution for all receivers in the video wall to output to their connected displays.
- **Aspect Ratio:** Select the aspect ratio logic to use when presenting a source across the video wall. Selecting “Best Fit” will maintain the aspect ratio of the original source while filling the video wall as much as possible and adding black bars where necessary. Selecting “Full Screen” will stretch the source to fit the video wall, regardless of the original source’s aspect ratio.
- **Wall Size:** Select the size of the video wall, measured in number of monitors tall by number of monitors wide. The maximum number of displays in a single video wall is 64 (8x8).
- **Bezel Top/Bottom/Left/Right:** Set the size, in pixels, of the bezel surrounding the monitors used in the video wall.

Note: It is strongly recommended to use the same make and model for all displays within a video wall to avoid bezel and panel size discrepancies.

- **Receiver Selection:** This is a list of all available receivers in the system. Drag and drop each receiver to its correct position within the video wall grid to the right of the list. After placement, each receiver’s name will be displayed within the selected location of the video wall and it will turn red or green. Green panels within the video wall indicate that a display has been assigned and is in video wall mode, red panels indicate that a display has been assigned, but is not active/ in the correct mode, and blue panels indicate that no display has been assigned yet.
- **Save Group:** Click this button to save changes to the current video wall configuration without executing or activating it.
- **Execute:** Click this button to save changes to the current video wall configuration and then execute the changes. If the video wall was not already active, this will also activate it.

6.6.8 Multiview Tab

This tab provides a way to configure or modify the multiviewer functionality of each receiver. All aspects of a multiviewer output can be configured here including window number and arrangement, output resolution, and window sources.

Note: Using a source within a multiviewer output will increase the bandwidth requirements of the associated transmitter. The increase in bandwidth usage depends on the pixel size of the window required by the multiview output and the frame rate of the source. In order to minimize the bandwidth impact with 4K sources, it is strongly recommended to enable the “Multiview Divide FPS by two” feature of the transmitter.

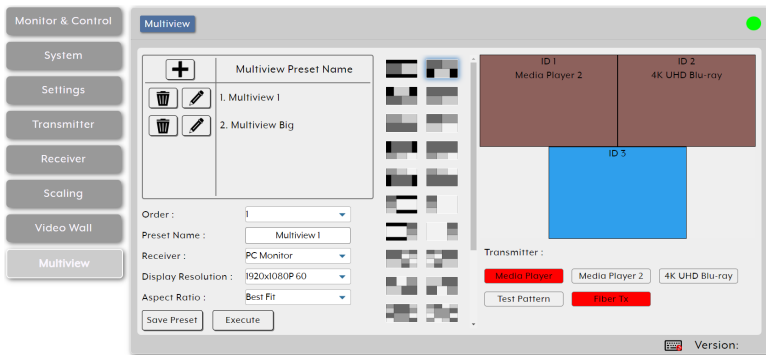

- 1) **Multiview Preset List:** The upper left section of this tab contains a list of all currently defined multiview presets in the system and provides a way to create new presets, edit them, or delete them. To add a new preset, click on the “Add” icon (+) and then select the preferred options and window configuration. To edit an existing preset, click on the “Edit” icon (✎) and then make whatever changes are required. Once a new or edited multiview preset has been configured, click on the “Save Preset” button at the bottom of the page to store the preset’s configuration. To save and immediately activate the current multiview preset, click on the “Execute” button. To delete an existing preset, click on the “Delete” icon (🗑️) next to the appropriate preset’s name.

Note: Deleting a multiview preset will not disable the multiview output it described if it is currently active. To completely remove a multiview output, a new source needs to be routed to the display, or the output needs to be disabled from the Monitor & Control Tab.

- **Order:** Use the dropdown to reorder the video wall groups in the list. Changing the order here will also change the order the groups are listed in other tabs.
- **Preset Name:** Set the name of the multiview preset here.
- **Receiver:** Select the receiver to display the multiview output when the “Execute” button is used.
- **Display Resolution:** Select the output resolution for the multiview receiver.
- **Aspect Ratio:** Select the aspect ratio logic to use when displaying sources within their multiview windows. Selecting “Best Fit” will maintain the aspect ratio of the original source while filling the window as much as possible and adding black bars where necessary. Selecting “Full Screen” will stretch a source to fit the window, regardless of the original source’s aspect ratio.

Note: This setting applies to all sources/windows within the current multiview preset.

- **Multiview Layout Selection:** This is a scrollable list of premade multiviewer layout designs. Click on the design that best matches your preferred layout and source count requirements to place it in the layout window to the right.

Note: Customized layouts are not currently supported.

- **Transmitter Selection:** This is a list of all available transmitters in the system. Drag and drop each transmitter to its preferred position within the multiview layout above the list. After placement, each transmitter’s name will be displayed within the selected window in the multiview layout and the window will turn red or green. A green window indicates that a source has been assigned and is active, a red window indicates that a source has been assigned but is not active, and a blue panel indicates that no source has been assigned yet.
- **Save Preset:** Click this button to save changes to the current multiview configuration without activating it.
- **Execute:** Click this button to save changes to the current multiview configuration and then activate the preset on the display defined by the “Receiver” setting.

6.7 Telnet Control

Before attempting to use Telnet control, please ensure that both the unit and the PC are connected to the same active networks.

To Access the Command Line Interface (CLI)	
Windows 7	Click Start , type “cmd” in the search field, and press Enter .
Windows XP	Click Start > Run , type “cmd”, and press Enter .
Mac OS X	Click Go > Applications > Utilities > Terminal .

Once in the Command Line Interface (CLI) type “**telnet**” followed by the IP address of the unit (and the port number if it is non-standard) and then hit “**Enter**”. This will connect us to the unit we wish to control.

```
Microsoft Windows [Version 6.1.7601]
Copyright (c) 2009 Microsoft Corporation. All rights reserved.

C:\Users\Administrator>telnet 192.168.1.50 23
```

Note 1: If the IP address is changed then the IP address required for Telnet access will also change accordingly.

Note 2: This unit defaults to DHCP mode. The current IP address can be verified using the HDMI output or RS-232 if the Device Discovery software is not available.

6.8 RS-232 and Telnet Commands

COMMAND				
Description and Parameters				
<p>help↵</p> <p>Show the full command list.</p>				
<p>help N1↵</p> <p>Show details about the specified command.</p> <p>N1 = {Command}</p>				
<p>?↵</p> <p>Show the full command list.</p>				
<p>? N1↵</p> <p>Show details about the specified command.</p> <p>N1 = {Command}</p>				
<p>get fw ver↵</p> <p>Show the unit's current firmware version.</p>				
<p>set factory default↵</p> <p>Reset the unit to the factory defaults.</p>				
<p>get command ver↵</p> <p>Show the unit's current command version.</p>				
<p>get model name↵</p> <p>Show the unit's model name.</p>				
<p>get model type↵</p> <p>Show the unit's product type.</p>				
<p>get mac N1 addr↵</p> <p>Show the MAC address of the specified LAN port.</p> <p>Available values for N1:</p> <table data-bbox="193 1284 676 1342"> <tr> <td>1</td> <td>[LAN port 1]</td> </tr> <tr> <td>2</td> <td>[LAN port 2]</td> </tr> </table>	1	[LAN port 1]	2	[LAN port 2]
1	[LAN port 1]			
2	[LAN port 2]			
<p>set factory ipconfig default↵</p> <p>Reset the unit's network settings to the factory defaults.</p>				

COMMAND									
Description and Parameters									
set system reboot ↵	Reboot the unit.								
set lan N1 ip mode N2 ↵	<p>Set the IP address assignment mode of the specified LAN port.</p> <p>Available values for N1:</p> <table border="0"> <tr> <td>1</td> <td>[LAN Port 1]</td> </tr> <tr> <td>2</td> <td>[LAN Port 2]</td> </tr> </table> <p>Available values for N2:</p> <table border="0"> <tr> <td>Static</td> <td>[Static IP mode]</td> </tr> <tr> <td>DHCP</td> <td>[DHCP mode]</td> </tr> </table>	1	[LAN Port 1]	2	[LAN Port 2]	Static	[Static IP mode]	DHCP	[DHCP mode]
1	[LAN Port 1]								
2	[LAN Port 2]								
Static	[Static IP mode]								
DHCP	[DHCP mode]								
get lan N1 ip mode ↵	<p>Show the current IP address assignment mode of the specified LAN port.</p> <p>Available values for N1:</p> <table border="0"> <tr> <td>1</td> <td>[LAN Port 1]</td> </tr> <tr> <td>2</td> <td>[LAN Port 2]</td> </tr> </table>	1	[LAN Port 1]	2	[LAN Port 2]				
1	[LAN Port 1]								
2	[LAN Port 2]								
get lan N1 ipconfig ↵	<p>Show the specified LAN port's current IP configuration information.</p> <p>Available values for N1:</p> <table border="0"> <tr> <td>1</td> <td>[LAN Port 1]</td> </tr> <tr> <td>2</td> <td>[LAN Port 2]</td> </tr> </table>	1	[LAN Port 1]	2	[LAN Port 2]				
1	[LAN Port 1]								
2	[LAN Port 2]								
get lan N1 ipaddr ↵	<p>Show the specified LAN port's current IP address.</p> <p>Available values for N1:</p> <table border="0"> <tr> <td>1</td> <td>[LAN Port 1]</td> </tr> <tr> <td>2</td> <td>[LAN Port 2]</td> </tr> </table>	1	[LAN Port 1]	2	[LAN Port 2]				
1	[LAN Port 1]								
2	[LAN Port 2]								
get lan N1 netmask ↵	<p>Show the specified LAN port's current netmask.</p> <p>Available values for N1:</p> <table border="0"> <tr> <td>1</td> <td>[LAN Port 1]</td> </tr> <tr> <td>2</td> <td>[LAN Port 2]</td> </tr> </table>	1	[LAN Port 1]	2	[LAN Port 2]				
1	[LAN Port 1]								
2	[LAN Port 2]								

COMMAND	
Description and Parameters	
get lan N1 gateway ↵	
Show the specified LAN port's current gateway address.	
Available values for N1 :	
1	[LAN Port 1]
2	[LAN Port 2]
set lan N1 static ipaddr N2 ↵	
Set the specified LAN port's static IP address.	
Available values for N1 :	
1	[LAN Port 1]
2	[LAN Port 2]
N2 = X.X.X.X	[X = 0~255, IP address]
get lan N1 static ipaddr ↵	
Show the specified LAN port's current static IP address.	
Available values for N1 :	
1	[LAN Port 1]
2	[LAN Port 2]
set lan N1 static netmask N2 ↵	
Set the specified LAN port's static netmask.	
Available values for N1 :	
1	[LAN Port 1]
2	[LAN Port 2]
N2 = X.X.X.X	[X = 0~255, netmask]
get lan N1 static netmask ↵	
Show the specified LAN port's current static netmask.	
Available values for N1 :	
1	[LAN Port 1]
2	[LAN Port 2]

COMMAND	
Description and Parameters	
set lan N1 static gateway N2 ↵	
Set the specified LAN port's static gateway address.	
Available values for N1 :	
1	[LAN Port 1]
2	[LAN Port 2]
N2 = X.X.X.X	[X = 0~255, gateway address]
get lan N1 static gateway ↵	
Show the specified LAN port's current static gateway address.	
Available values for N1 :	
1	[LAN Port 1]
2	[LAN Port 2]
get uart list ↵	
List all available serial ports.	
set uart N1 reset ↵	
Reset the specified serial port's settings to the factory defaults.	
Available values for N1 :	
1	[3-pin serial port]
2	[5-pin serial port]
set uart N1 baudrate N2 ↵	
Set the baud rate of the specified serial port.	
Available values for N1 :	
1	[3-pin serial port]
2	[5-pin serial port]
Available values for N2 :	
2400	[2400 baud]
4800	[4800 baud]
9600	[9600 baud]
19200	[19200 baud]
38400	[38400 baud]
57600	[57600 baud]
115200	[115200 baud]

COMMAND	
Description and Parameters	
get uart N1 baudrate↵	
Show the current baud rate of the specified serial port.	
Available values for N1 :	
1	[3-pin serial port]
2	[5-pin serial port]
set uart N1 stop bit N2↵	
Set the number of stop bits for the specified serial port.	
Available values for N1 :	
1	[3-pin serial port]
2	[5-pin serial port]
Available values for N2 :	
1	[1 stop bit]
2	[2 stop bits]
get uart N1 stop bit↵	
Show the current number of stop bits for the specified serial port.	
Available values for N1 :	
1	[3-pin serial port]
2	[5-pin serial port]
set uart N1 data bit N2↵	
Set the data bits used by the specified serial port.	
Available values for N1 :	
1	[3-pin serial port]
2	[5-pin serial port]
Available values for N2 :	
7	[7 data bits]
8	[8 data bits]
get uart N1 data bit↵	
Show the current number of data bits used by the specified serial port.	
Available values for N1 :	
1	[3-pin serial port]
2	[5-pin serial port]

COMMAND

Description and Parameters

set uart N1 parity N2↵

Set the parity of the specified serial port.

Available values for **N1**:

1	[3-pin serial port]
2	[5-pin serial port]

Available values for **N2**:

0	[None]
1	[Odd]
2	[Even]

get uart N1 parity↵

Show the current parity setting of the specified serial port.

Available values for **N1**:

1	[3-pin serial port]
2	[5-pin serial port]

set uart 2 mode N1↵

Set the operational mode of the Control Output (5-pin) serial port.

Available values for **N1**:

0	[Disabled]
1	[RS-232 mode]
2	[RS-422 mode]
3	[RS-485 mode]

get uart 2 mode↵

Show the current operational mode of the Control Output (5-pin) serial port.

set uart 2 command [N1]↵

Transmit the specified command data via the Control Output (5-pin) serial port.

N1 = {Command data} [ASCII text]

Note: To transmit hex data, each ASCII hex pair (octet) must be preceded by “\x”. For example a carriage return would be “\x0D”.

COMMAND

Description and Parameters

set voip N1 audio out oN2 route N3 n4↵

Route the specified transmitter's audio input to the specified receiver's audio output.

N1 = rx1~rx128 [Receiver device ID]

Available values for **N2**:

1 [HDMI audio output]

2 [Analog audio output]

N3 = tx1~tx128 [Transmitter device ID]

Available values for **N4**:

1 [HDMI audio input]

2 [Analog audio input]

*Note: The values for **N2** and **N4** must match.*

set all voip audio out oN1 route N2 N3↵

Route the specified transmitter's audio input to all receivers' audio outputs.

Available values for **N1**:

1 [HDMI audio output]

2 [Analog audio output]

N2 = tx1~tx128 [Transmitter device ID]

Available values for **N3**:

1 [HDMI audio input]

2 [Analog audio input]

*Note: The values for **N1** and **N3** must match.*

set tx N1 uart 1 command [N2]↵

Transmit the specified command data via the serial port on the specified transmitter.

N1 = 1~128 [Transmitter device ID]

N2 = {Command data} [ASCII text]

Note: To transmit hex data, each ASCII hex pair (octet) must be preceded by "x". For example a carriage return would be "x0D".

COMMAND

Description and Parameters

set rx N1 uart 1 command [N2]↵

Transmit the specified command data via the serial port on the specified receiver.

N1 = 1~128 [Receiver device ID]

N2 = {Command data} [ASCII text]

Note: To transmit hex data, each ASCII hex pair (octet) must be preceded by “\x”. For example a carriage return would be “\x0D”.

set all tx uart command [N1]↵

Transmit the specified command data via the serial port on all transmitters.

N1 = {Command data} [ASCII text]

Note: To transmit hex data, each ASCII hex pair (octet) must be preceded by “\x”. For example a carriage return would be “\x0D”.

set all rx uart command [N1]↵

Transmit the specified command data via the serial port on all receivers.

N1 = {Command data} [ASCII text]

Note: To transmit hex data, each ASCII hex pair (octet) must be preceded by “\x”. For example a carriage return would be “\x0D”.

set voip N1 uart route N2↵

Route the specified transmitter or receiver’s serial port Rx pin to the serial port Tx pin on the specified transmitter or receiver.

Available values for **N1**:

tx1~tx128 [Transmitter device ID (Tx pin)]

rx1~rx128 [Receiver device ID (Tx pin)]

Available values for **N2**:

tx1~tx128 [Transmitter device ID (Rx pin)]

rx1~rx128 [Receiver device ID (Rx pin)]

COMMAND	
Description and Parameters	
set all voip uart route N1 ↵	
Route the specified transmitter or receiver's serial port Rx pin to all AVoIP devices' serial port Tx pins.	
Available values for N1 :	
tx1~tx128	[Transmitter device ID]
rx1~rx128	[Receiver device ID]
set tx N1 ir 1 command [N2] ↵	
Transmit the specified IR data via the IR output on the specified transmitter.	
N1 = 1~128	[Transmitter device ID]
N2 = {IR ASCII hex data}	[Pronto format IR data]
set rx N1 ir 1 command [N2] ↵	
Transmit the specified IR data via the IR output on the specified receiver.	
N1 = 1~128	[Receiver device ID]
N2 = {IR ASCII hex data}	[Pronto format IR data]
set all tx ir command [N1] ↵	
Transmit the specified IR data via the IR outputs on all transmitters.	
N1 = {IR ASCII hex data}	[Pronto format IR data]
set all rx ir command [N1] ↵	
Transmit the specified IR data via the IR outputs on all receivers.	
N1 = {IR ASCII hex data}	[Pronto format IR data]

COMMAND	
Description and Parameters	
set voip N1 ir route N2 ↵	
Route the specified transmitter or receiver's IR input to the IR output on the specified transmitter or receiver.	
Available values for N1 :	
tx1~tx128	[Transmitter device ID (IR output)]
rx1~rx128	[Receiver device ID (IR output)]
Available values for N2 :	
tx1~tx128	[Transmitter device ID (IR input)]
rx1~rx128	[Receiver device ID (IR input)]
set all voip ir route N1 ↵	
Route the specified transmitter or receiver's IR input to all AVoIP devices' IR outputs.	
Available values for N1 :	
tx1~tx128	[Transmitter device ID (IR input)]
rx1~rx128	[Receiver device ID (IR input)]
set voip N1 usb device o1 route N2 1 ↵	
Route the specified AVoIP device's USB device to the specified AVoIP device's USB host.	
Available values for N1 :	
tx1~tx128	[Transmitter device ID (USB device)]
rx1~rx128	[Receiver device ID (USB device)]
Available values for N2 :	
tx1~tx128	[Transmitter device ID (USB host)]
rx1~rx128	[Receiver device ID (USB host)]
set video wall preset N1 ↵	
Execute the specific video wall configuration.	
N1 = 1~128	[Video wall group ID]
set multiview preset N1 ↵	
Execute the specific multiview preset.	
N1 = 1~128	[Multiview preset ID]

COMMAND**Description and Parameters****set macro N1 run↵**

Execute the specified macro immediately.

N1 = 1~16 [Macro ID]

*Note: Commands will not be executed unless followed by a carriage return.
Commands are not case-sensitive.*

7. CONNECTION DIAGRAM

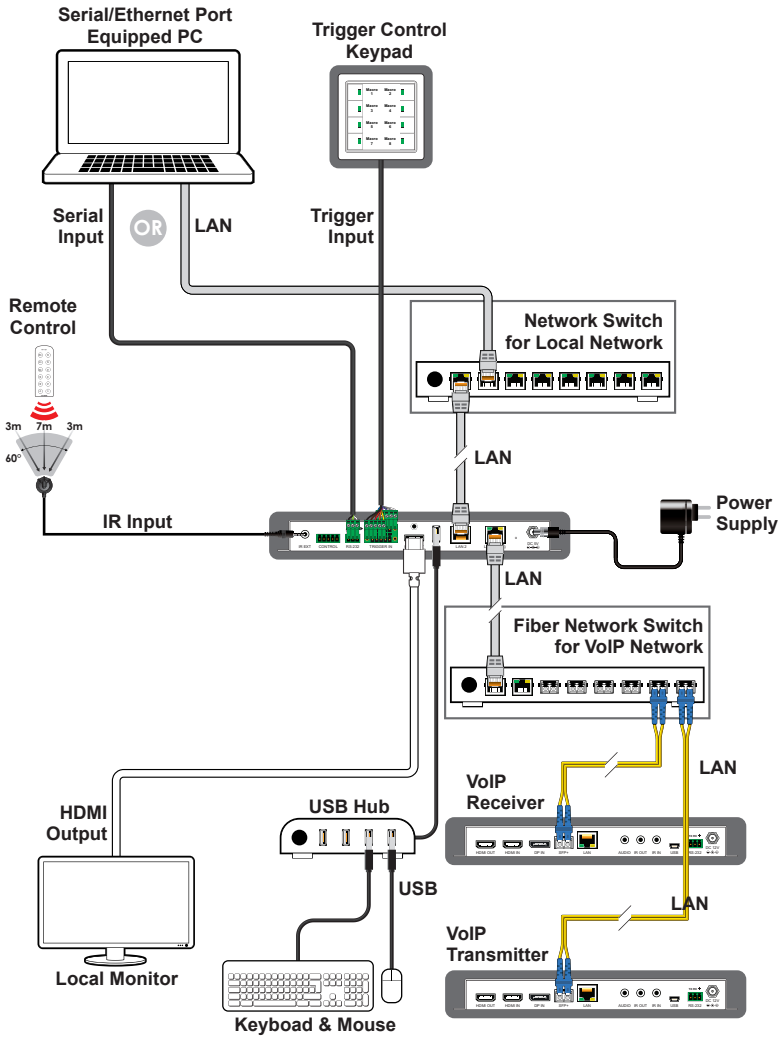

8. SPECIFICATIONS

8.1 Technical Specifications

HDMI Output Resolution	1920×1080@60Hz
Output Ports	1×HDMI (Type-A) 1×RS-232 (5-pin Terminal Block)
Control Ports	1×IR Extender (3.5mm) 1×RS-232 (3-pin Terminal Block) 8×Trigger (10-pin Terminal Block) 2×LAN (RJ-45) 1×USB 2.0 (Type A)
IR Frequency	38kHz
Baud Rate	19200
Power Supply	5V/2.6A DC (US/EU standards, CE/FCC/UL certified)
ESD Protection (HBM)	±8kV (Air Discharge) ±4kV (Contact Discharge)
Dimensions (W×H×D)	231.5mm×25mm×108mm [Case Only] 231.5mm×25mm×117mm [All Inclusive]
Weight	648g
Chassis Material	Metal (Steel)
Chassis Color	Black
Operating Temperature	0°C – 40°C/32°F – 104°F
Storage Temperature	-20°C – 60°C/-4°F – 140°F
Relative Humidity	20 – 90% RH (Non-condensing)
Power Consumption	7.35W

8.2 Video Specifications

Supported Resolutions (Hz)	Output
	HDMI
720×400p@70/85	x
640×480p@60/72/75/85	x
720×480i@60	x
720×480p@60	x
720×576i@50	x
720×576p@50	x
800×600p@56/60/72/75/85	x
848×480p@60	x
1024×768p@60/70/75/85	x
1152×864p@75	x
1280×720p@50/60	x
1280×768p@60/75/85	x
1280×800p@60/75/85	x
1280×960p@60/85	x
1280×1024p@60/75/85	x
1360×768p@60	x
1366×768p@60	x
1400×1050p@60	x
1440×900p@60/75	x
1600×900p@60RB	x
1600×1200p@60	x
1680×1050p@60	x
1920×1080i@50/60	x
1920×1080p@24/25/30	x
1920×1080p@50/60	60
1920×1200p@60RB	x

Supported Resolutions (Hz)	Output
	HDMI
2560×1440p@60RB	×
2560×1600p@60RB	×
2048×1080p@24/25/30	×
2048×1080p@50/60	×
3840×2160p@24/25/30	×
3840×2160p@50/60 (4:2:0)	×
3840×2160p@24, HDR10	×
3840×2160p@50/60 (4:2:0), HDR10	×
3840×2160p@50/60	×
4096×2160p@24/25/30	×
4096×2160p@50/60 (4:2:0)	×
4096×2160p@24, HDR10	×
4096×2160p@50/60 (4:2:0), HDR10	×
4096×2160p@50/60	×

8.3 Cable Specifications

Cable Length	1080p		4K30	4K60
	8-bit	12-bit	(4:4:4) 8-bit	(4:4:4) 8-bit
High Speed HDMI Cable				
HDMI Output	15m	x	x	x

Bandwidth Category Examples:

- **1080p (FHD Video)**
 - Up to 1080p@60Hz, 12-bit color
 - Data rates lower than 5.3Gbps or below 225MHz TMDS clock
- **4K30 (4K UHD Video)**
 - 4K@24/25/30Hz & 4K@50/60Hz (4:2:0), 8-bit color
 - Data rates higher than 5.3Gbps or above 225MHz TMDS clock but below 10.2Gbps
- **4K60 (4K UHD⁺ Video)**
 - 4K@50/60Hz (4:4:4, 8-bit)
 - 4K@50/60Hz (4:2:0, 10-bit HDR)
 - Data rates higher than 10.2Gbp

9. ACRONYMS

ACRONYM	COMPLETE TERM
10GbE	10 Gigabit Ethernet
ADC	Analog-to-Digital Converter
ASCII	American Standard Code for Information Interchange
AVoIP	Audio/Video over IP
AVR	Audio/Video Receiver or Recorder
Cat.5e	Enhanced Category 5 cable
Cat.6	Category 6 cable
Cat.6A	Augmented Category 6 cable
Cat.7	Category 7 cable
CLI	Command-Line Interface
DAC	Digital-to-Analog Converter
DHCP	Dynamic Host Configuration Protocol
DP	DisplayPort
EDID	Extended Display Identification Data
GbE	Gigabit Ethernet
GUI	Graphical User Interface
HDCP	High-bandwidth Digital Content Protection
HDMI	High-Definition Multimedia Interface
HDR	High Dynamic Range
HDTV	High-Definition Television
IGMP	Internet Group Management Protocol
IP	Internet Protocol
IR	Infrared
KVM	Keyboard/Video/Mouse
LAN	Local Area Network
LED	Light-Emitting Diode
LPCM	Linear Pulse-Code Modulation
MAC	Media Access Control

ACRONYM	COMPLETE TERM
OSD	On-Screen Display
PD	Powered Device
SDVoE	Software Defined Video over Ethernet
TCP	Transmission Control Protocol
4K UHD	4K Ultra-High-Definition (10.2Gbps max)
4K UHD⁺	4K Ultra-High-Definition (18Gbps max)
UHDTV	Ultra-High-Definition Television
USB	Universal Serial Bus
VLAN	Virtual LAN
VoIP	Video over IP
WUXGA (RB)	Widescreen Ultra Extended Graphics Array (Reduced Blanking)
XGA	Extended Graphics Array



CYPRESS TECHNOLOGY CO., LTD.
www.cypress.com.tw
